

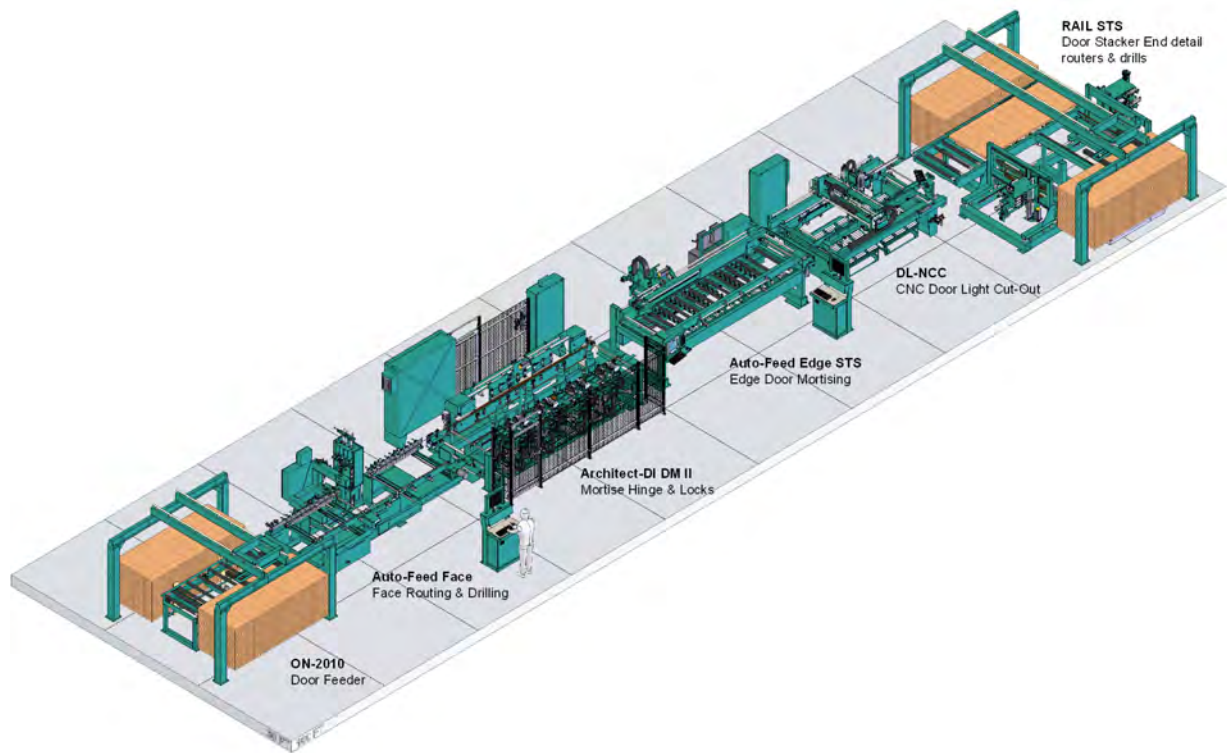

Innovation, Quality & Honesty

# Alliance Series Lubrication Points

Published: 10/20/08



---

---

---

# Table of Contents

<b>CHAPTER 1</b>	<i>Safety First!</i>	<b>1-1</b>
	Lock Out Procedure	1-3
	To lock out an <i>Alliance Series</i> machine	1-3
	Lockout and Tagout Guidelines	1-4
	Follow the P-R-O-P-E-R lockout rule of thumb.	1-4
<b>CHAPTER 2</b>	<i>ON-2010</i>	<b>2-1</b>
<b>CHAPTER 3</b>	<i>FACE</i>	<b>3-1</b>
	FACE - Grease Points	3-3
	Main Frame	3-3
	Head	3-3
	Auto Feed System (Optional)	3-4
<b>CHAPTER 4</b>	<i>Architect DI-DM</i>	<b>4-1</b>
	Set Up	4-3
	.....	4-3
	Architect DI-MD Grease Points	4-5
	Feed and Width Adjust	4-5
	Fixed Fence	4-5
	Movable Fence	4-6
	Front Section	4-7
	Head Position Axis	4-7
	Head Vertical Axis	4-7
	Head Horizontal Axis	4-8
	Head Main Z Axis and Router Z Axis	4-8
	Chisels	4-9
	Router	4-9
	Point to Point Drill	4-9
	4 Shooter	4-10
	Router Chipout	4-10
	Back Section	4-11
<b>CHAPTER 5</b>	<i>EDGE</i>	<b>5-1</b>
	Edge - Grease Points	5-3
	Feed System	5-3
	Movable Fence	5-3
	Edge Feelers	5-4
	Rollers	5-4
	Back Section	5-5

---

X-Axis	5-5
Y-Axis	5-6
Z-Axis	5-7
Routers	5-8
Point to Point Drill (Optional)	5-8
Chisels	5-9
Deep Mortise	5-10
<b>CHAPTER 6</b>	
<i>DLNCC</i>	<b>6-1</b>
DLNCC - Grease Points	6-3
Feed System	6-3
Fixed and Movable Fence	6-3
Tool Changer	6-4
X Axis	6-4
Y Axis	6-5
Cutting Head	6-5
Z Axis	6-5
Head Dust collection	6-6
Chisel (Optional)	6-6
Tool Calibration Bolt Eye	6-7
<b>CHAPTER 7</b>	
<i>RAIL</i>	<b>7-1</b>
Rail - Grease Points	7-3
Carriage	7-3
Roll Table	7-4
Rail	7-5
Fork Lift	7-5
Door Length Adjust	7-6
Cutting Heads	7-7
Cross Feed and Clamp	7-7
Door Stops	7-8
Width Edge Feeler	7-8
Length Edge Feeler	7-9
Y-Axis	7-10
X-Axis	7-11
Z-Axis	7-12
Tools	7-14
Chisels	7-14
Routers	7-14
Deep Drill (Optional)	7-14

## Introduction

This chapter provides a description of the *Alliance Series* product and identifies safety guidelines to ensure personnel safety and proper equipment use.

### Overview of the *Alliance Series*

The Alliance System functions as a single door machine with multiple stations controlled from a central console. Integrated KVAL software tracks each door as it progresses, automatically setting up the next station just as the door arrives. This allows the Alliance to machine five different doors for five different specifications simultaneously; no setup time is required between doors. Average productivity is one minute door-to-door for hinges and cylindrical or mortise locks:



- Squared hinges with screw holes.
- Cylinder locks with screw holes.
- Mortise locks with function holes.
- Card locks.
- Auto routing and squaring for vision panels.
- Viewer holes.
- T-Strikes.
- Flush bolts including deep drills to 12”.
- End detailing for closers, holders



# Safety First!

The *Alliance Series* machines are powerful electro-mechanical motion control systems. You should test your motion system for safety under all potential conditions. Failure to do so can result in damage to equipment and/or serious injury to personnel.

## Safety Guidelines

In addition to the caution and warning labels affixed to the *Alliance Series* machine, follow the guidelines below to help ensure the safety of equipment and personnel.

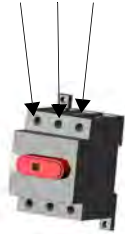
Guideline	Description
Safety Training	Ensure that all employees who operate this machine are aware of and adhere to all safety precautions posted on the machine and are trained to operate this machine in a safe manner.
Protective Gear	Never operate the machine without proper eye and ear protection.
Entering the Safety Cage	<p><b>When the machine is on:</b></p> <ul style="list-style-type: none"> <li>• Never reach hands beyond safety cage. Servo motors can unexpectedly move quickly and out of control.</li> <li>• Do not clear slugs out of the machine while it is running.</li> <li>• Never perform any maintenance while machine is running.</li> <li>• Never clean the machine while running.</li> <li>• Never walk away from the machine while running.</li> </ul>
Compressed Air	<p>The compressed air system connected to this machine should have a three-way air valve for shut-off and pressure relief. The air supply providing the pressure to this machine also has a three-way air valve for the supply line. All cylinders on machine are under high pressure and can be very dangerous when activated. Before performing any maintenance or repairs on machine turn the main air disconnect off. Lock out and tag out this connection.</p> 
Electrical	<p>Electrical circuitry on this machine is protected by an approved lockable disconnect circuit. In addition to this equipment, you must install an approved disconnect for the electrical power supplying this machine.</p> <p>When opening the cabinet you must first turn off the disconnect switch. When the cabinet door is open there is still power on the top side of the disconnect switch. All maintenance and repairs to electrical circuitry should only be performed by a qualified electrician.</p>  <p>Still has power in OFF position</p>
Before Conducting Maintenance	Prior to performing any maintenance, repairs, cleaning or when clearing jammed debris, you must disconnect, tag out, or lock out the electrical and air pressure systems. This should be done in accordance with the state and/or federal code requirements.
Compliance with Codes and Regulations	KVAL Inc. advises that you request an on-site state safety review of your installation of this machine. This is to ensure conformance to any additional specific safety and health regulations which apply in your geographic area.

Other Hazard Control Action	<p>If you believe any part or operation of this machine is in violation of any health or safety regulation, it is your responsibility to immediately protect your employees against any such hazard and bring the matter to our attention for review and correction, if deemed advisable.</p> <p>Additional detailed safety guidelines are included in the operating instructions of this manual. KVAL will be pleased to review with you any questions you may have regarding the safe operation of this machine.</p>
-----------------------------	--

---

## Lock Out Procedure

This policy is required by OSHA regulation 1910.147 and Cal OSHA'S SB198 ruling of July 1991.

Use the following lockout procedure to secure the *Alliance Series* machine while it is powered down. During a lockout, you disconnect all power and shut off the air supply. Be sure to use the tagout guidelines noted below.

### To lock out an *Alliance Series* machine

1. Assess the equipment to fully understand all energy sources (multiple electrical supplies, air supply and pressure, spring tension, weight shifts, etc.).
2. Inform all affected personnel of the eminent shutdown, and the duration of the shutdown.
3. Obtain locks, keys, and tags from your employer's lockout center.
4. Disconnect power
  - a. Turn the disconnect switches on the main electrical panel to the OFF position. Then pull out the red tab and place a padlock through the hole. Place your tag on the padlock, as per the tagout guidelines below. (see example below)



When multiple people are working on the machine, each person needs to have a lock on the handle in the extra holes provided.

- b. Turn the disconnect switch on the larger high-frequency panel to the OFF position. Then pull out the red tab and place a padlock through the hole. Place your tag on the padlock, as per the tagout guidelines below
5. Turn the main air valve to the OFF position and place a padlock through the hole (see illustration.).



**NOTE:** Place your tag on the padlock, as per the tagout guidelines below.

6. Once the locks and tags are in place and all personnel are clear, attempt to operate the machine to ensure equipment will not operate. When maintenance or repairs are completed, the person who performed the work must ensure all tools, spare parts, test equipment, etc., are completely removed and that all guards and safety devices are installed.
7. Before removing the locks and tags, the person who attached them shall inspect the equipment to ensure that the machine will not be put in an unsafe condition when re-energized.
8. The lock and tag can now be removed (only by the person(s) who placed them), and the machine can be re-energized.
9. The tags must be destroyed and the locks and keys returned to the lockout center.

## Lockout and Tagout Guidelines

- Place a tag on all padlocks. On the tags, include your name and date.
- These locks are only to be removed by the person on the tag.
- If more than one person is working on the machine, then each additional person places a lock and tag on each disconnect. You may only remove your own lock and tag.
- You may only remove your own lock and tag

**Note:** When many people are all working on the same machine you will need a multiple lockout device, such as the one shown here.



## Follow the P-R-O-P-E-R lockout rule of thumb.

- P.....** Process shutdown
- R .....** Recognize energy type (electrical, pneumatic, mechanical, etc.)
- O.....** OFF! Shut off all power sources and isolating devices
- P.....** Place lock and tag
- E.....** ENERGY: Release stored energy to a zero-energy state
- R .....** Recheck controls and test to insure they are in the “OFF” state

This chapter shows the lubrication points for the KVAL ON-2010.



Feed  
Direction

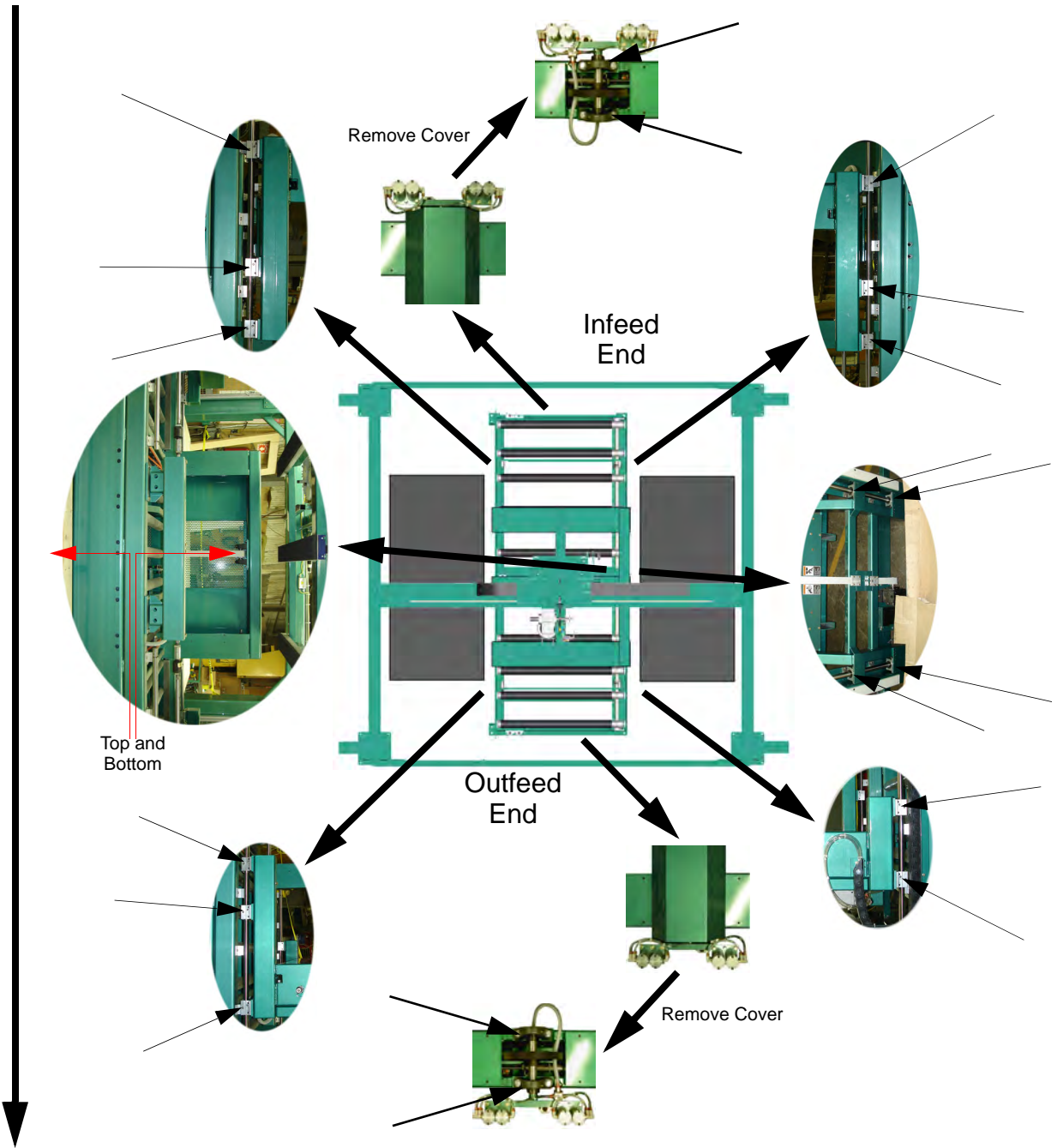

Top and  
Bottom

Top View

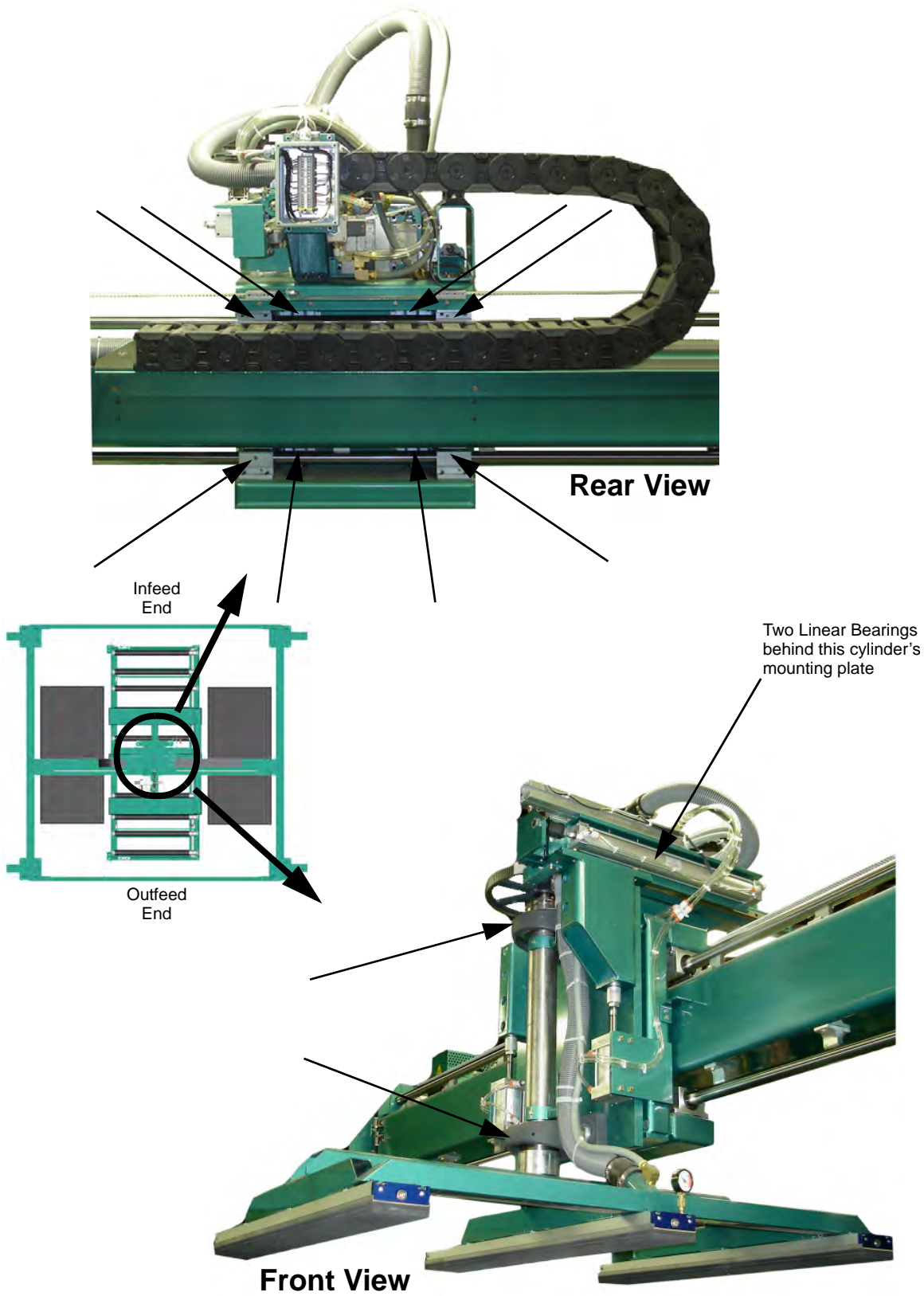

---

---

**CHAPTER 3**

**FACE**

This chapter shows the lubrication points for the KVAL FACE.



## FACE - Grease Points

### Main Frame

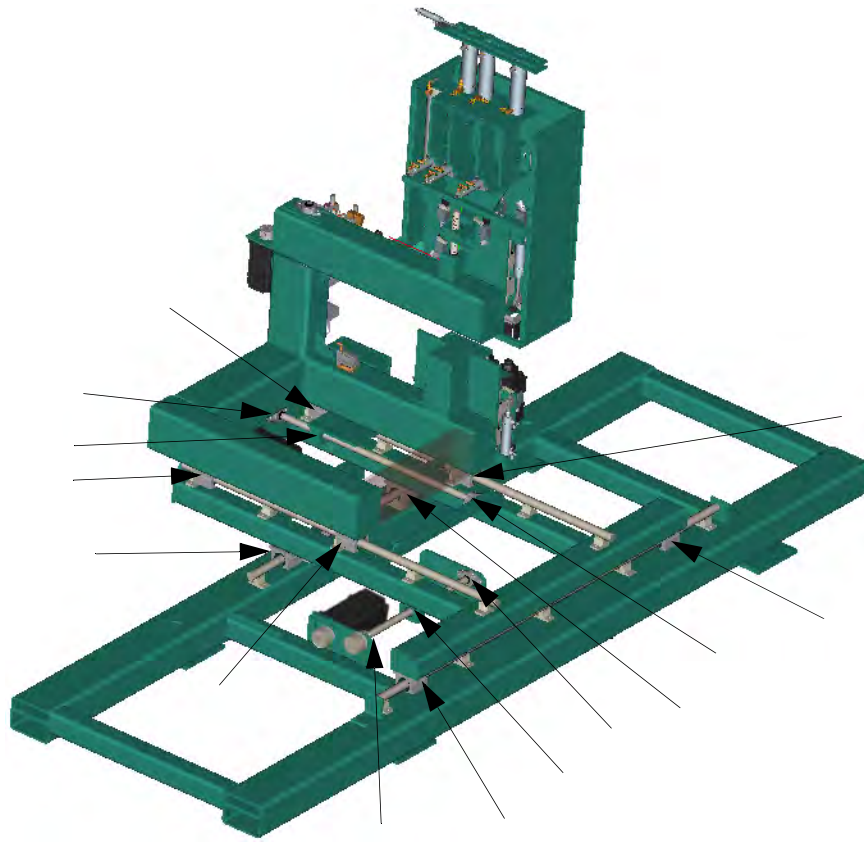

### Head

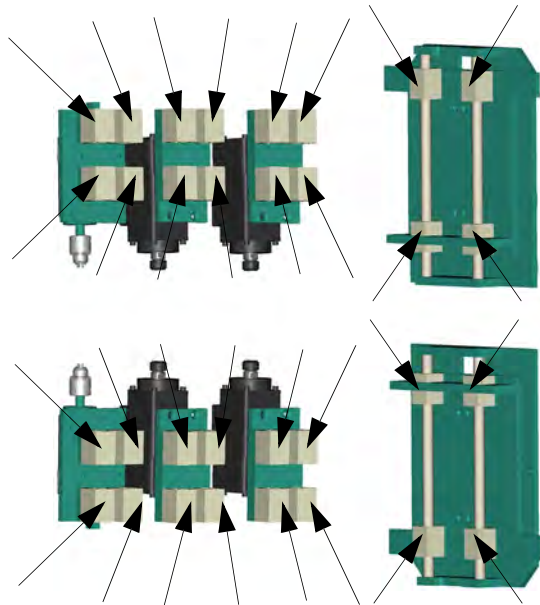

**Auto Feed System (Optional)**

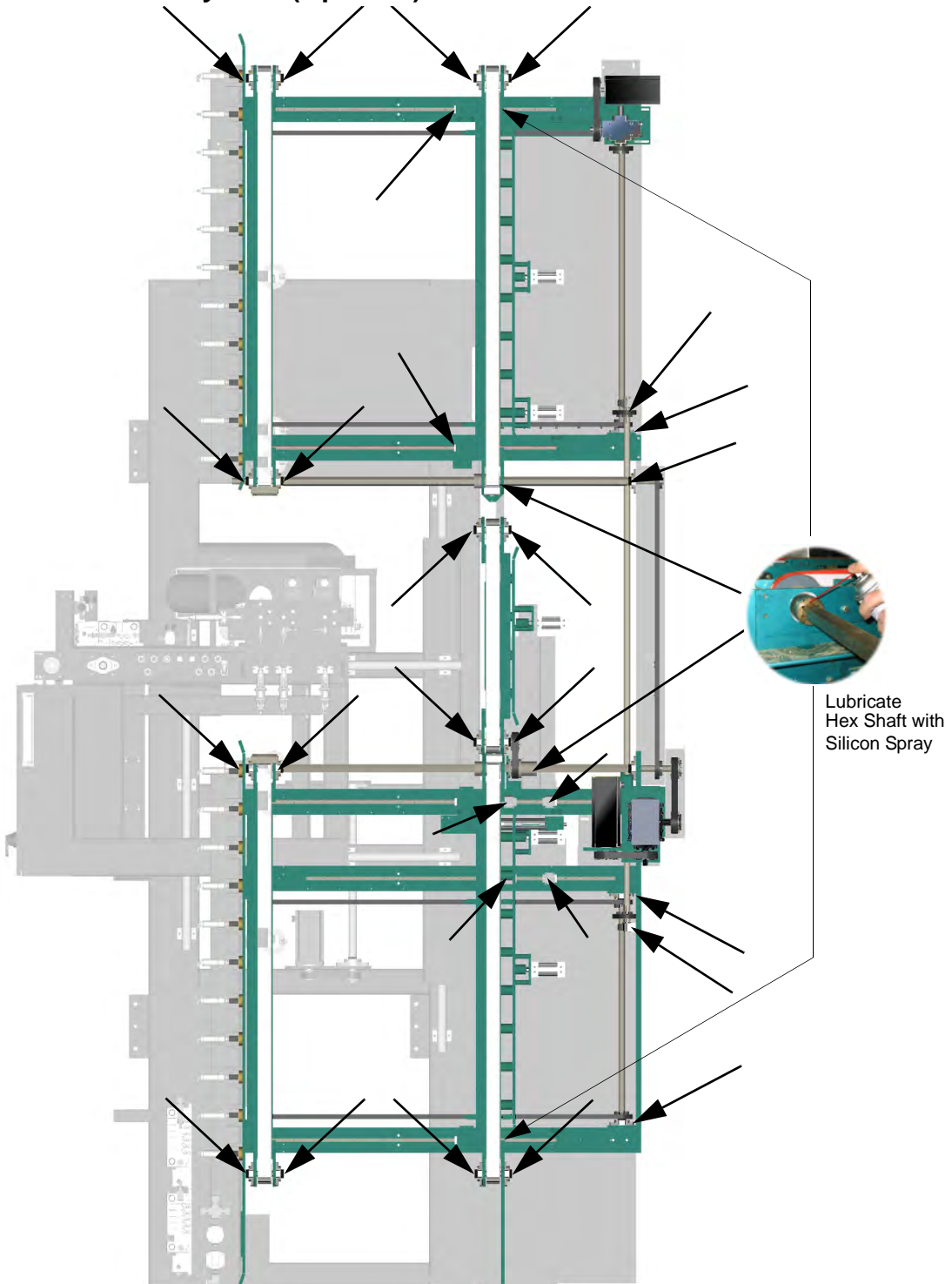

# **Architect DI-DM**

This chapter shows the lubrication points for the KVAL Architect DI-DM.



## Set Up

To access the front section lubrication points, all heads must be up and spaced apart. Use the Jog screens to move the heads. To get to these screens:

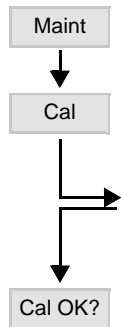

- a. On the PC, in the KVAL 2006 interface, click once on the **Maint** button.
- b. Click the **CAL** button.

A message pop up in front of the graphic display area.

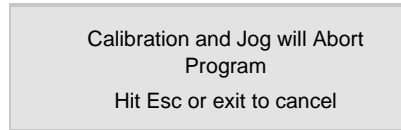

Click on the pop-up message to proceed.

- c. Click the **Cal OK?** button. The **Jog page** of the Calibration Menu page appears.

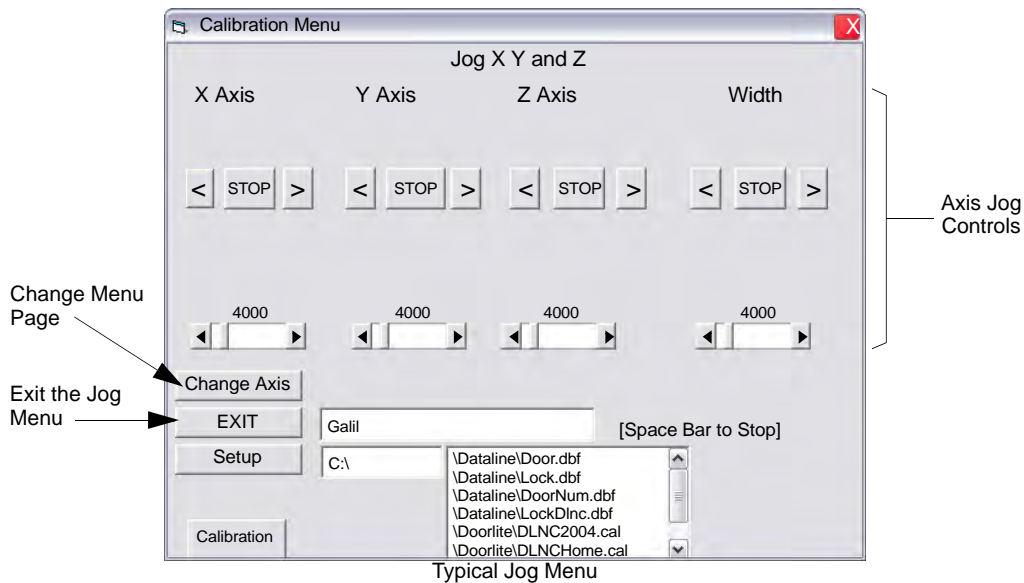

- d. Use the **Change Axis** button to find the desired Axis.

Face: Width and Feed

All others: Width

- e. Use the **Axis Jog Control** to move the axis to the desired position.

- f. Use the **Exit** button to return to the main menu.

### How to use the Axis Jog Control:

- a. Use **Speed Adjust** controls to adjust the servo speed to a workable rate.

**Note:** 4000 is a reasonable place to start.

- b. Use the **Start Move** and **Stop Move** buttons to move the servo axis to the desired location.

- c. Note: A **Start Move** button will start a axis in motion. The axis motion will continue until a **Stop Move** button is clicked.

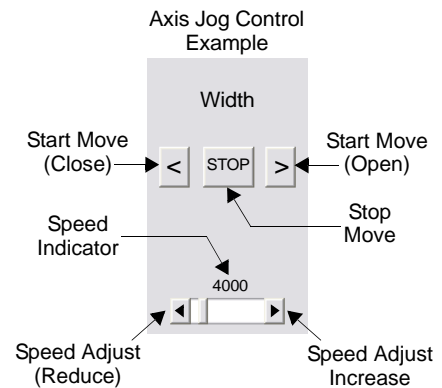



## Architect DI-MD Grease Points

### Feed and Width Adjust



**Fixed Fence**

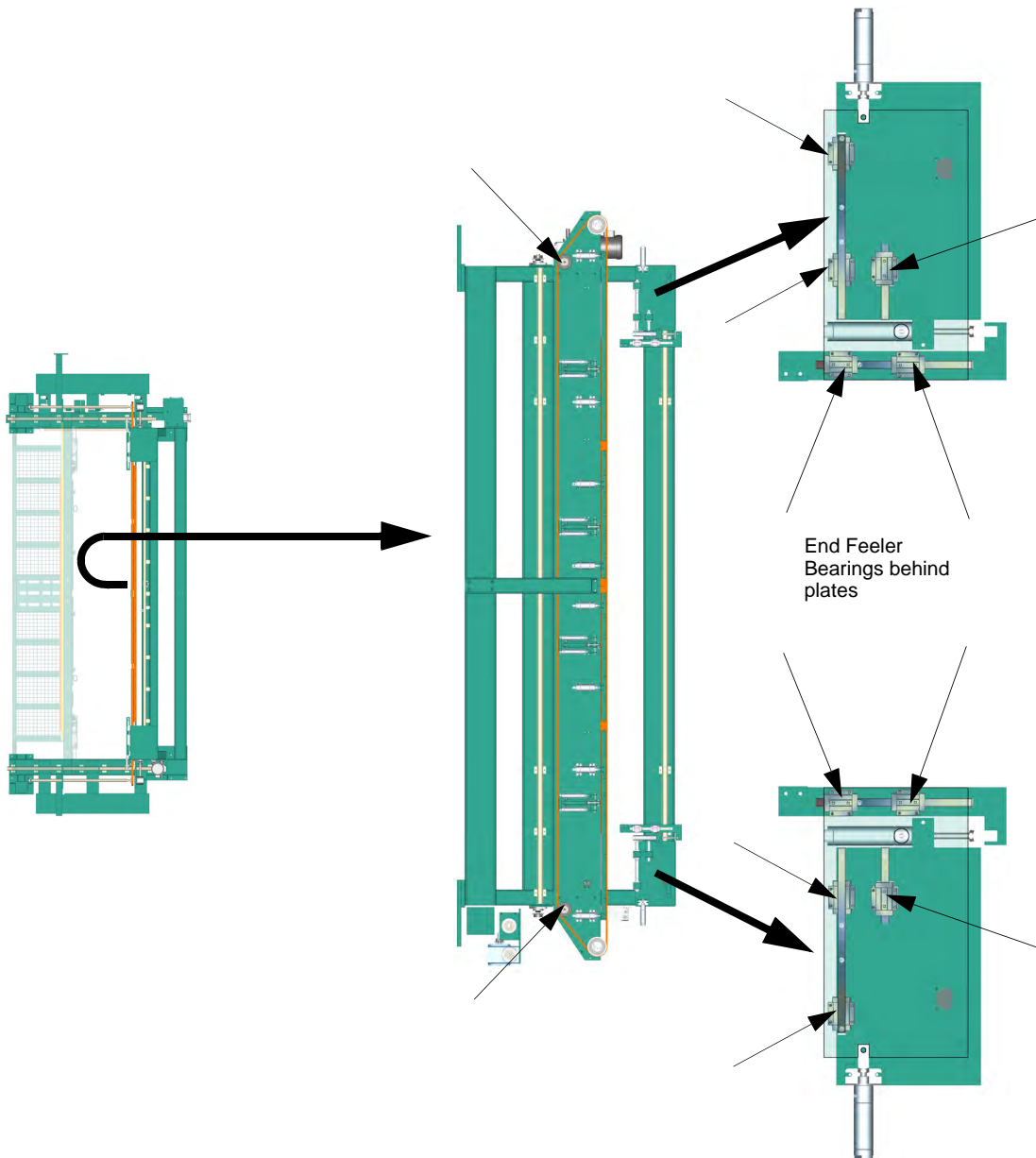

---

---

## Movable Fence

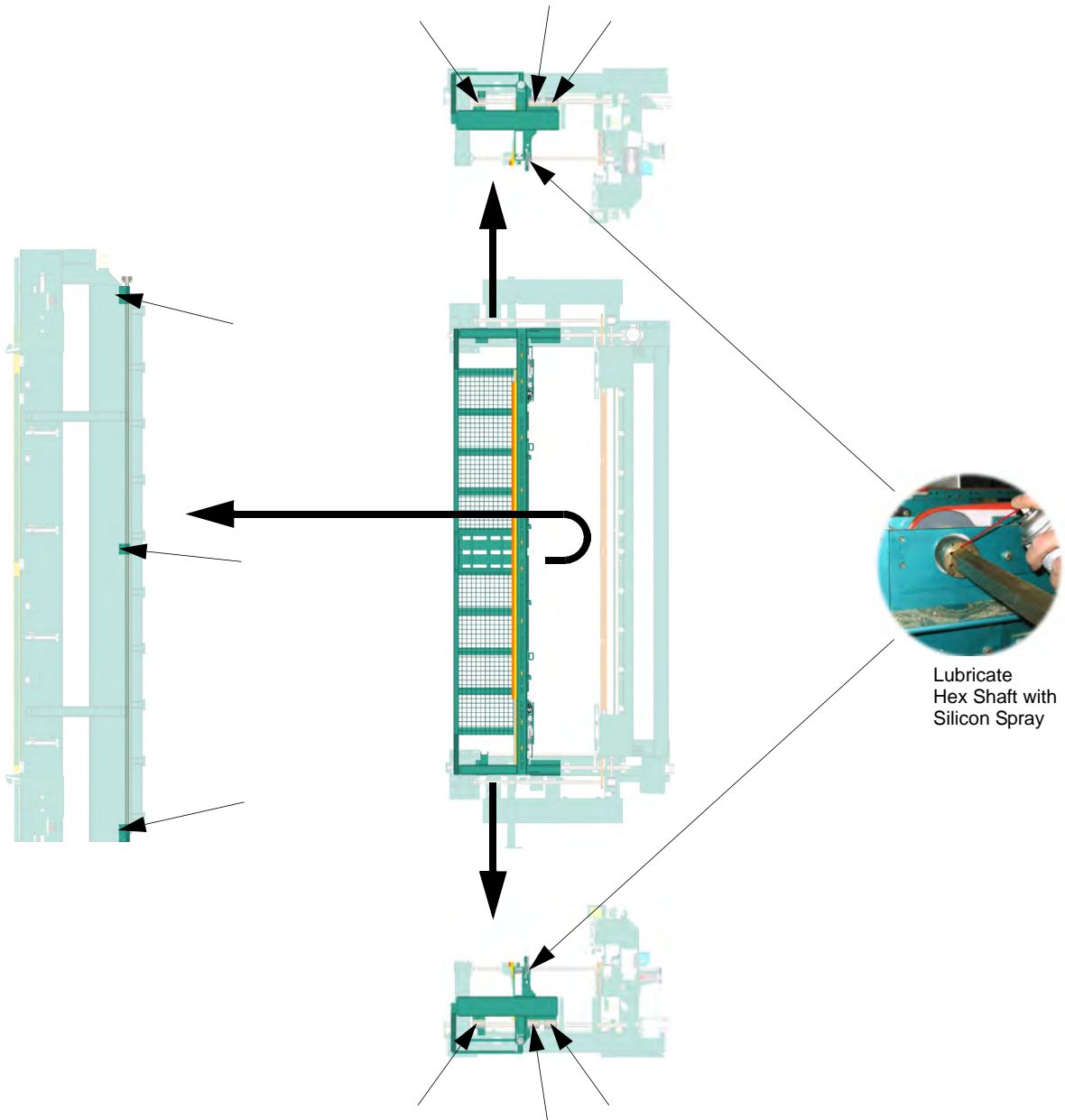

## Front Section

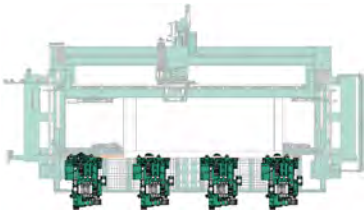

### Head Position Axis

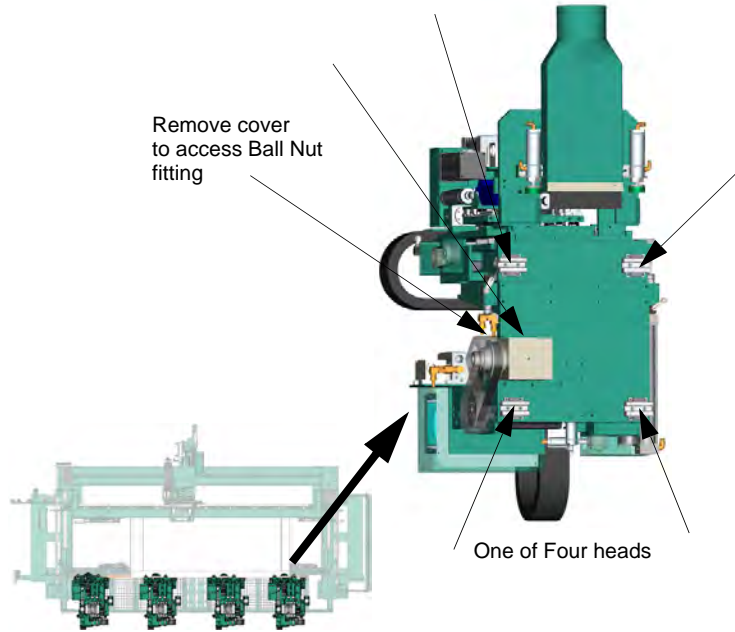

### Head Vertical Axis

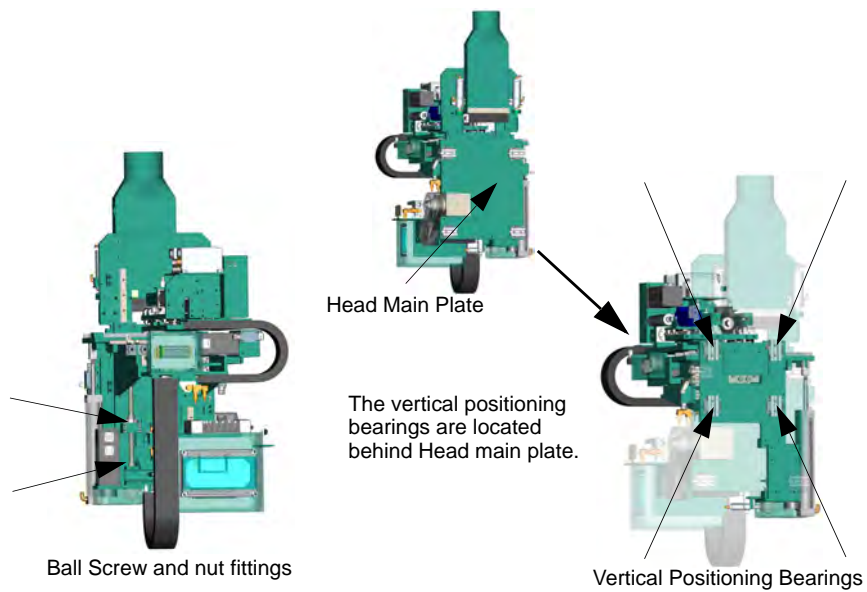

---

### Head Horizontal Axis

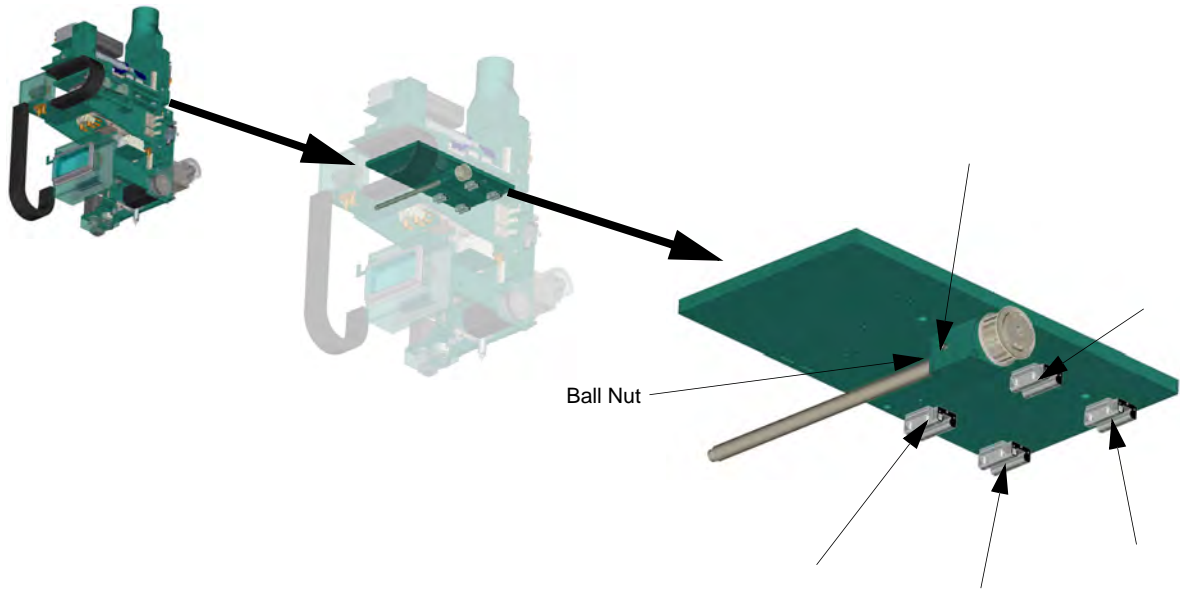

### Head Main Z Axis and Router Z Axis

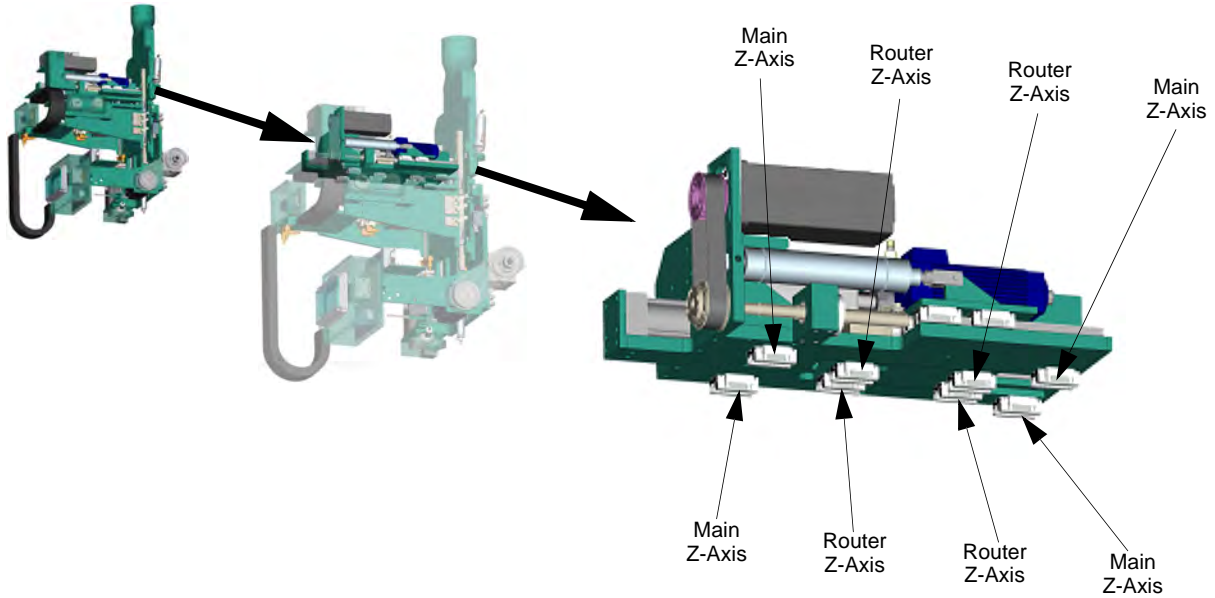

### Chisels

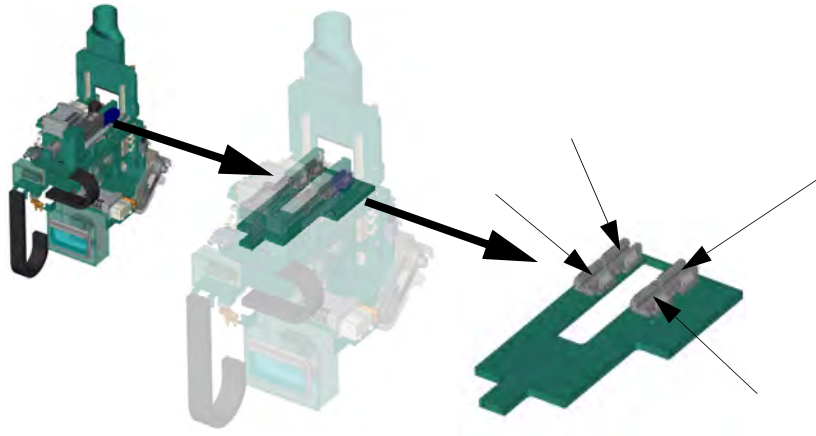

### Router

See “Head Main Z Axis and Router Z Axis” on page 4-8

### Point to Point Drill

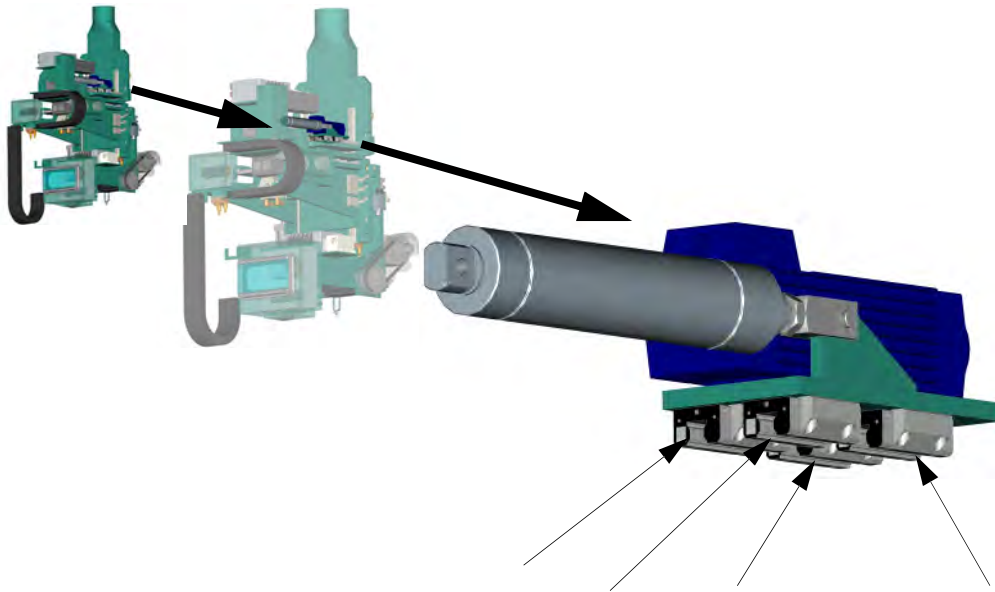

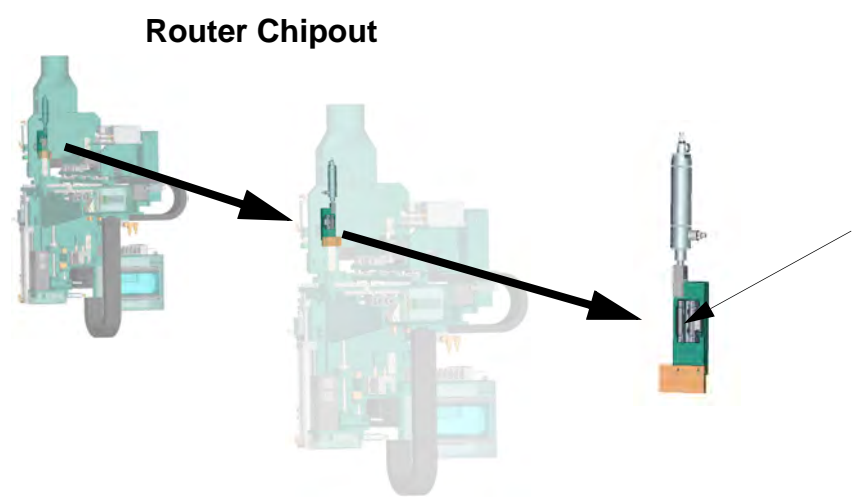
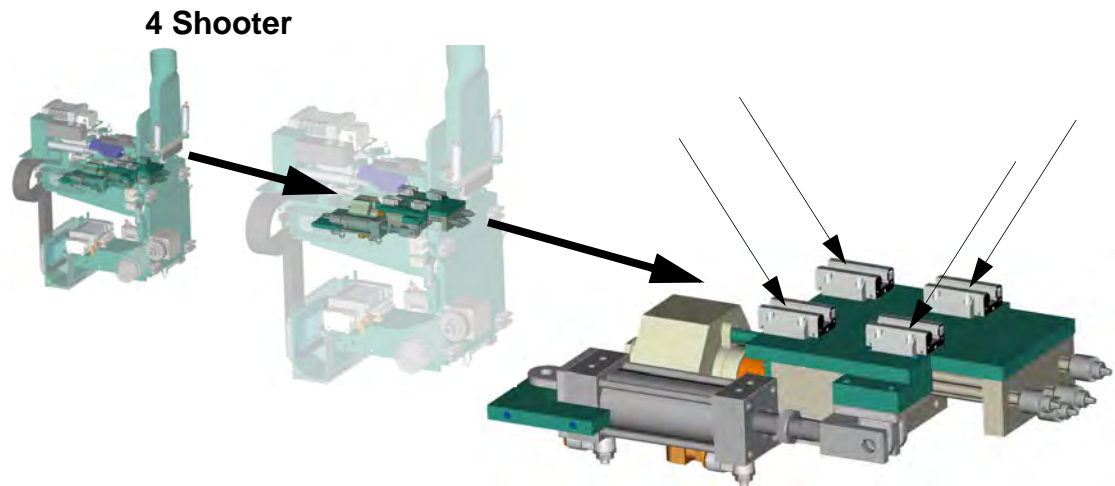

## Back Section

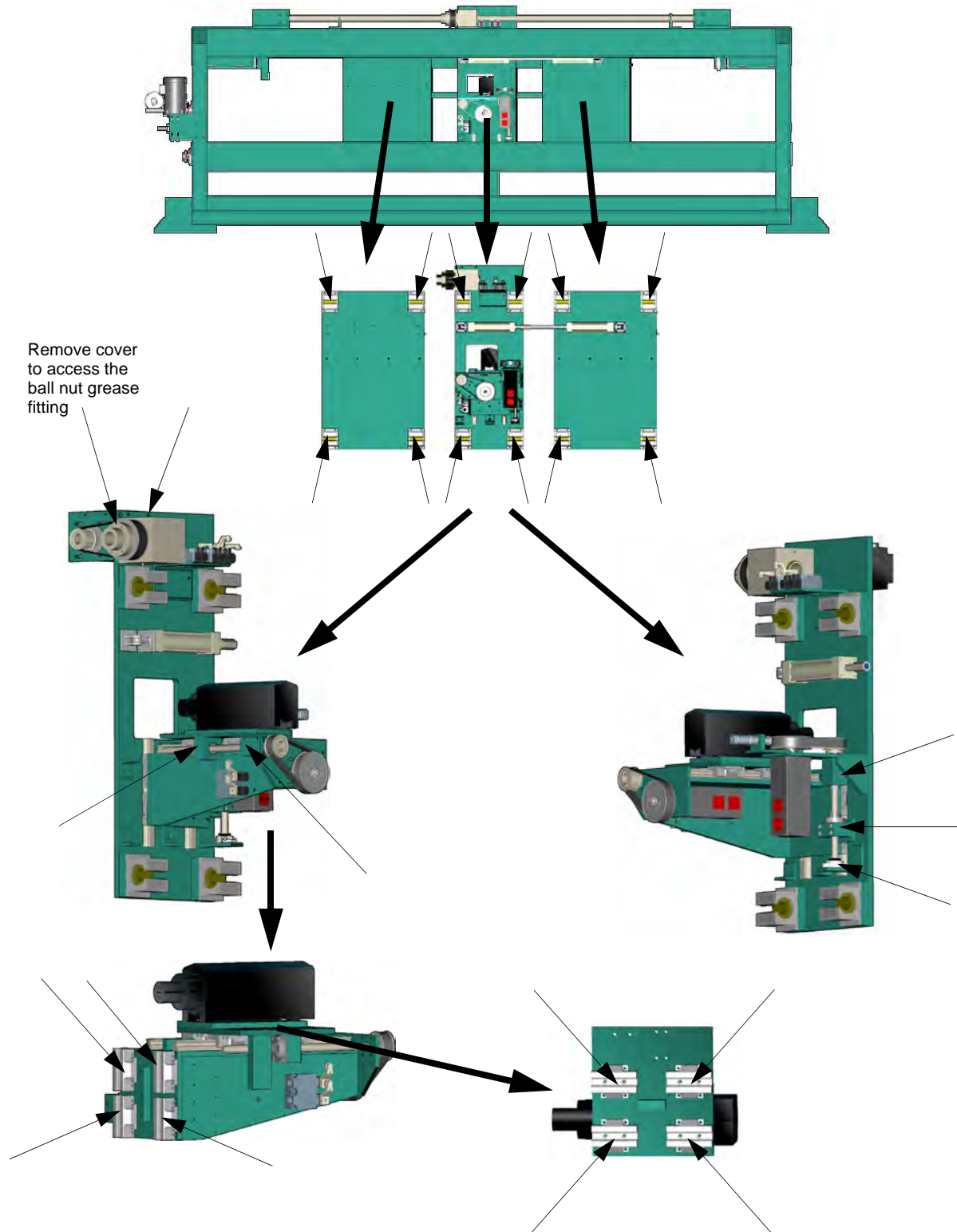



---

---

**CHAPTER 5**

**EDGE**

This chapter shows the lubrication points for the KVAL Edge.



## Edge - Grease Points

### Feed System

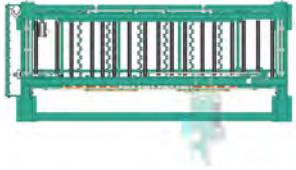

### Movable Fence

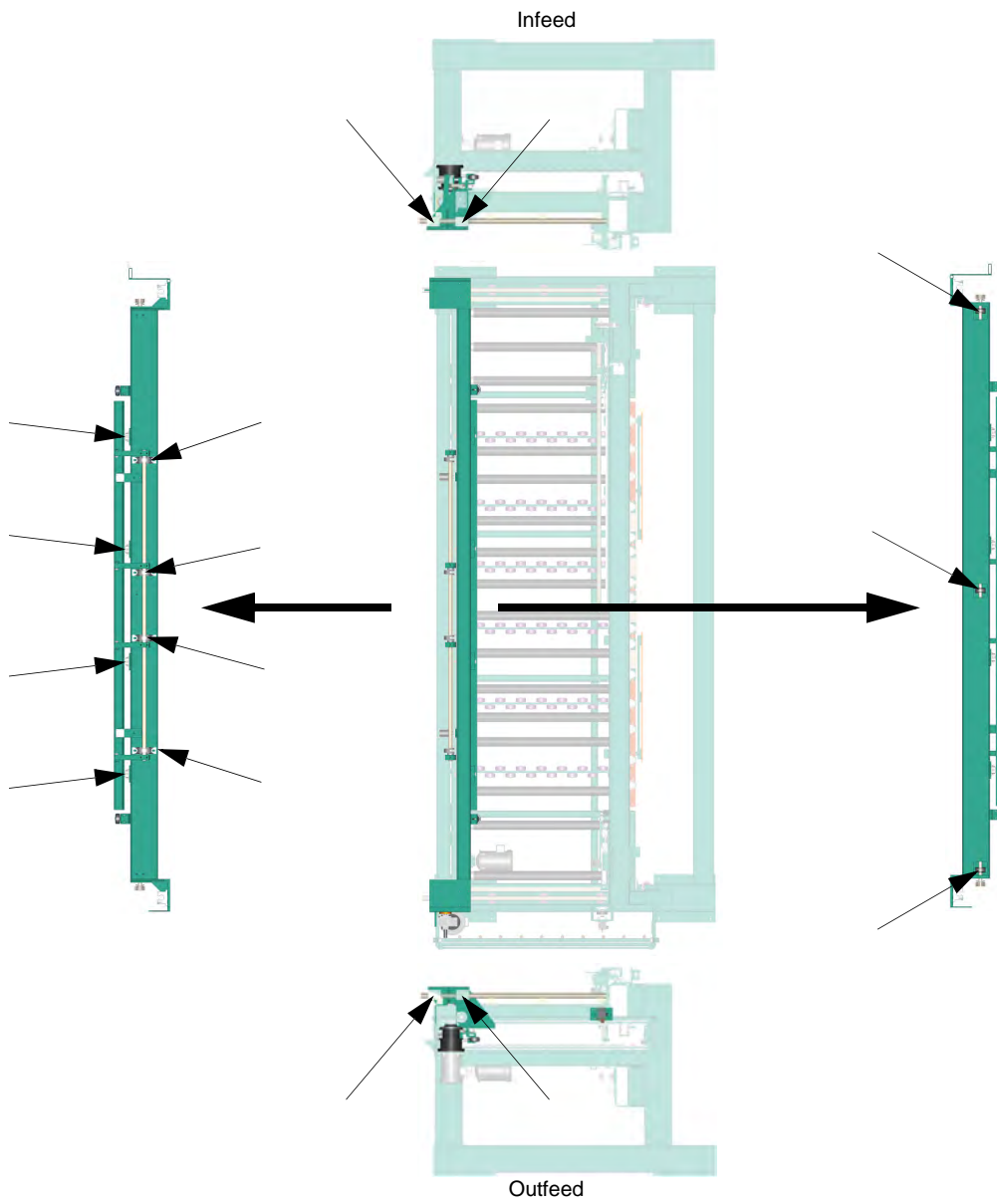

---

---

### Edge Feelers

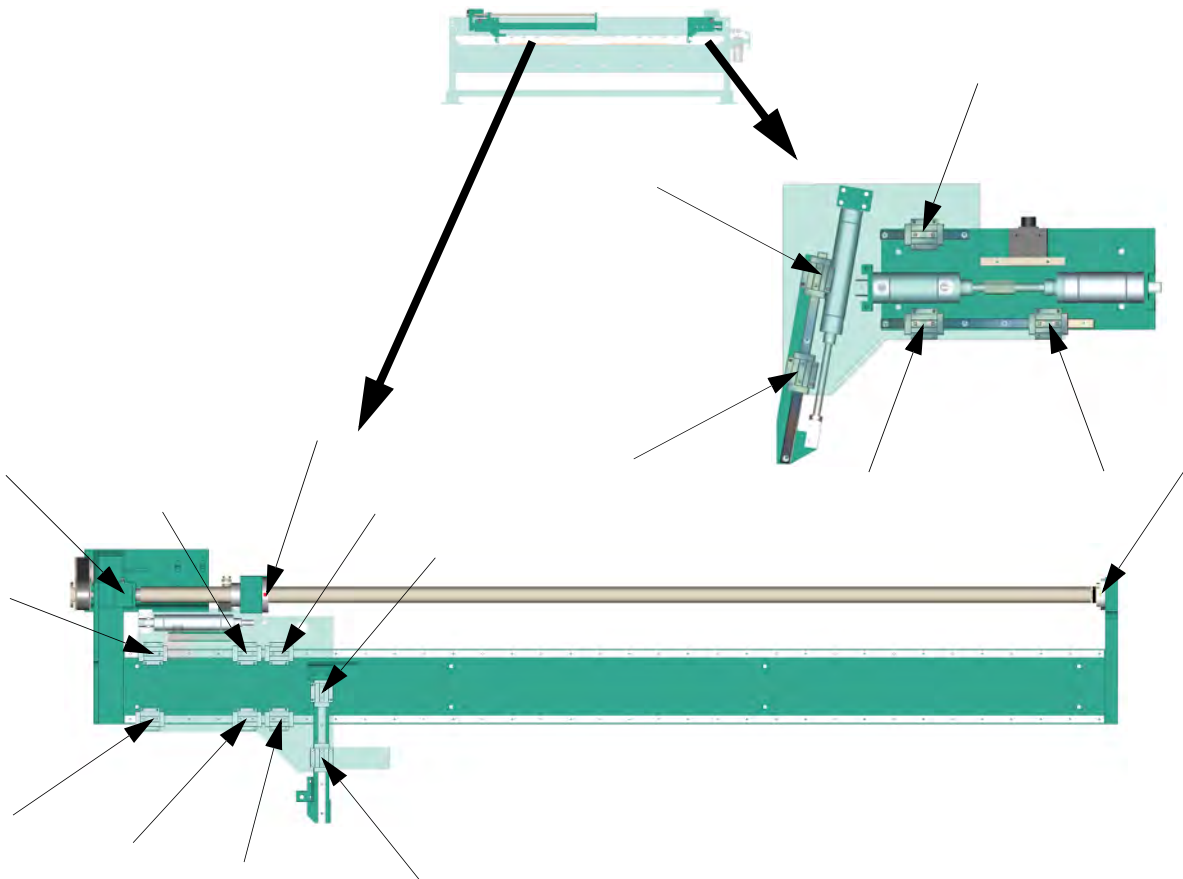

### Rollers

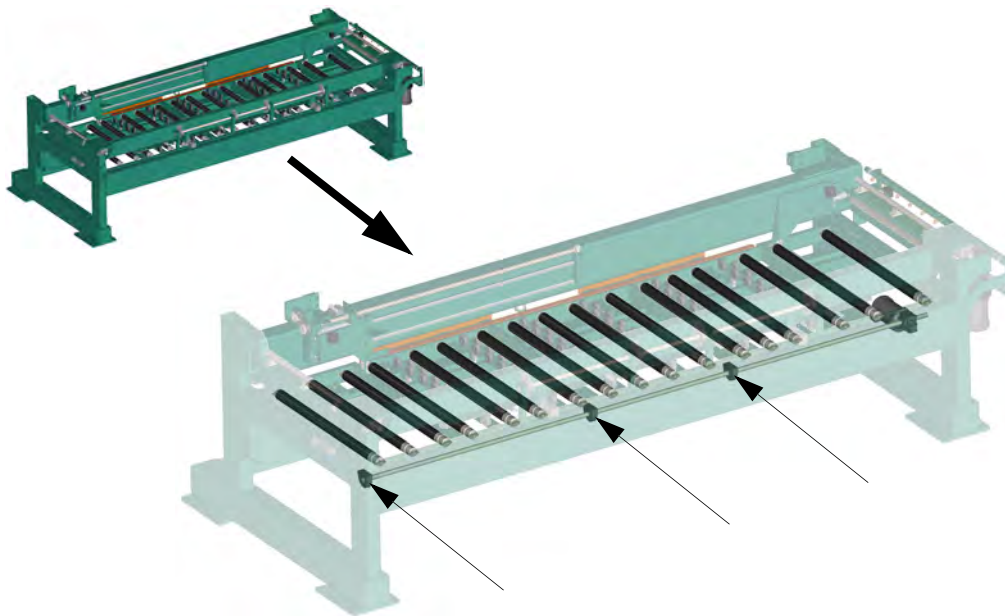

Back Section

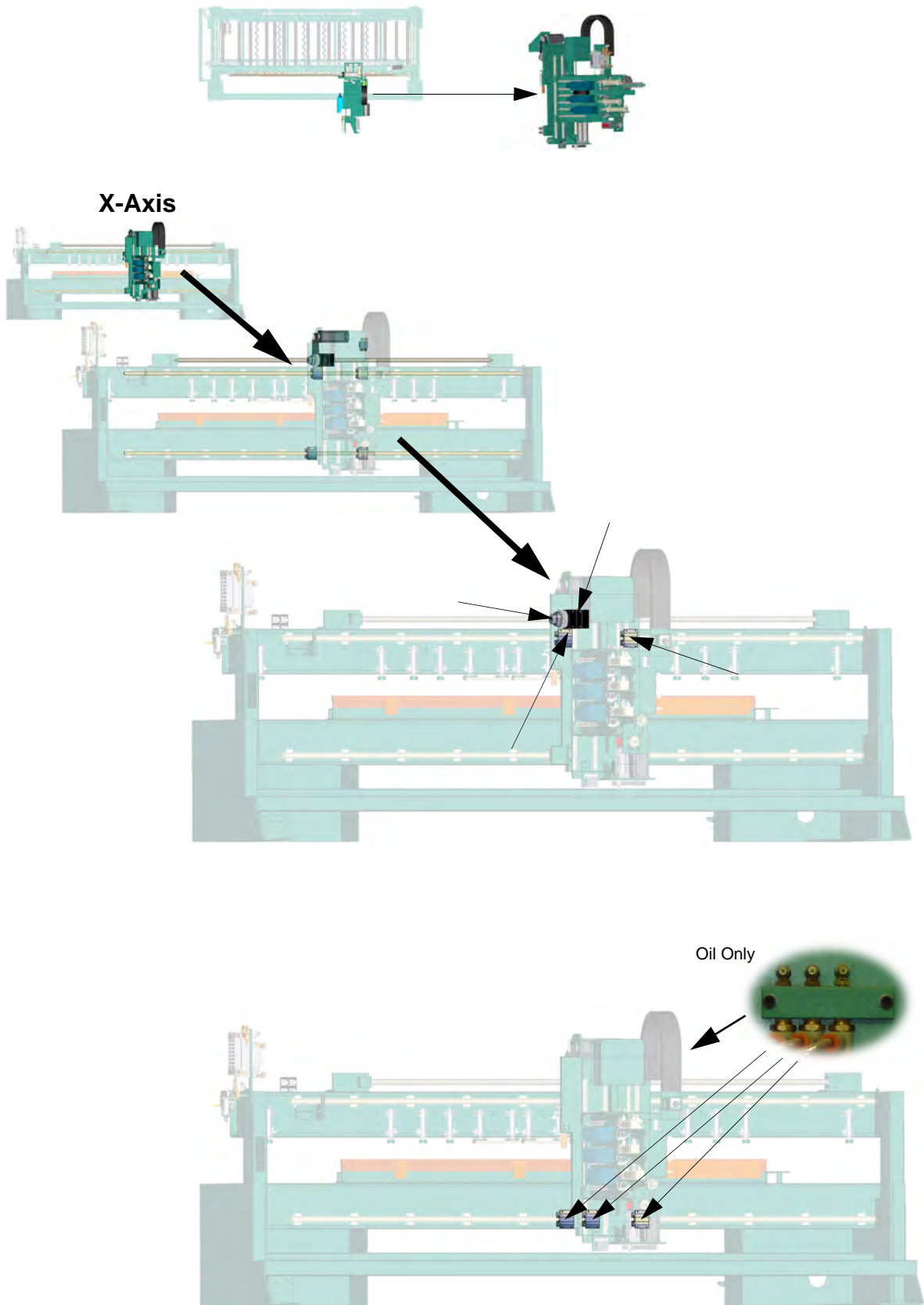

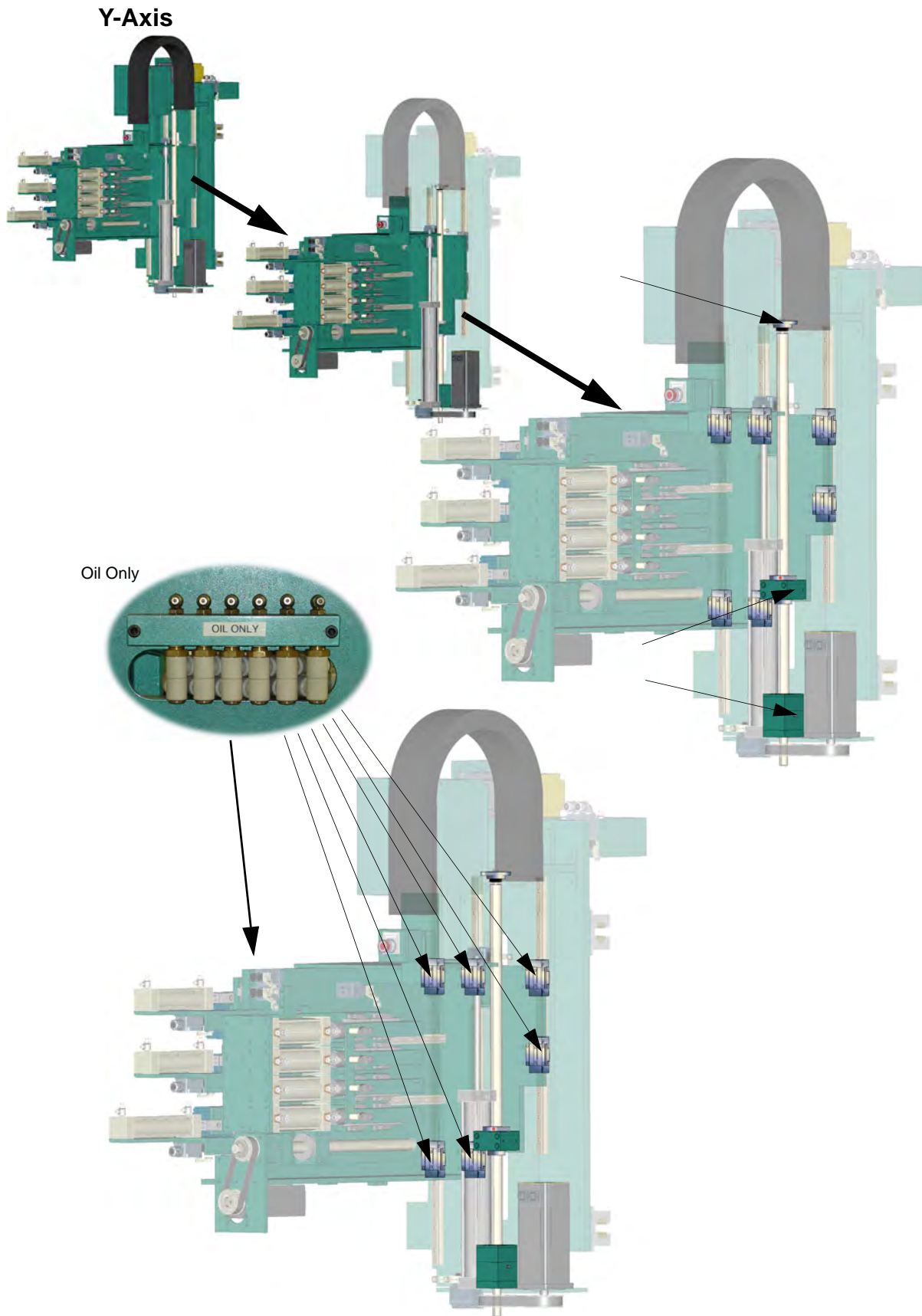

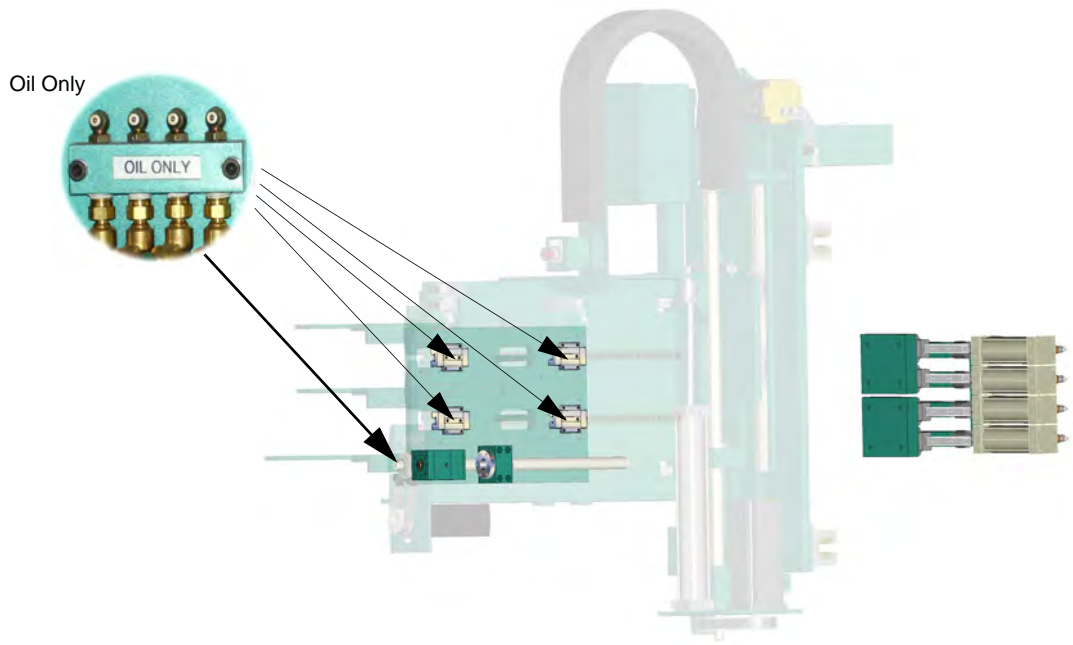
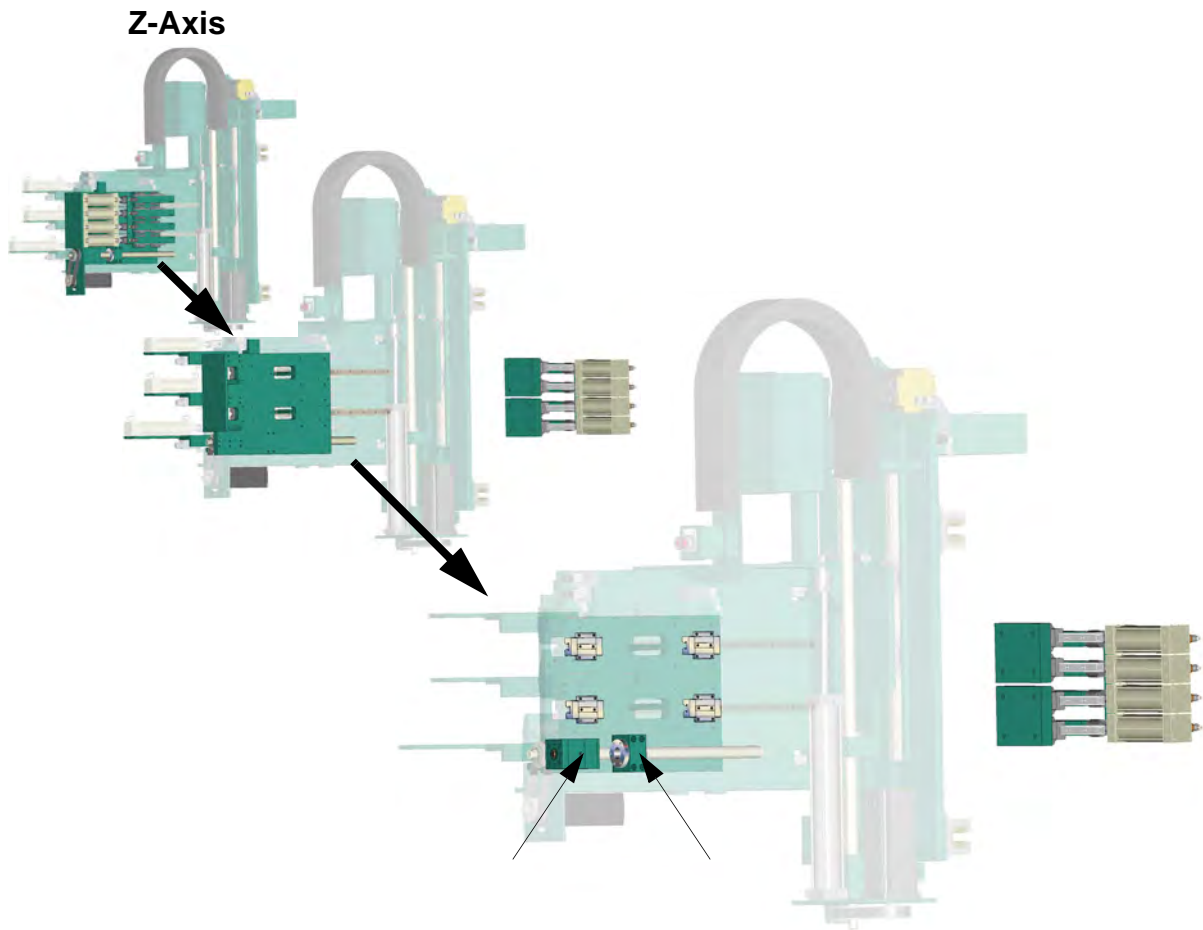

---

**Routers**

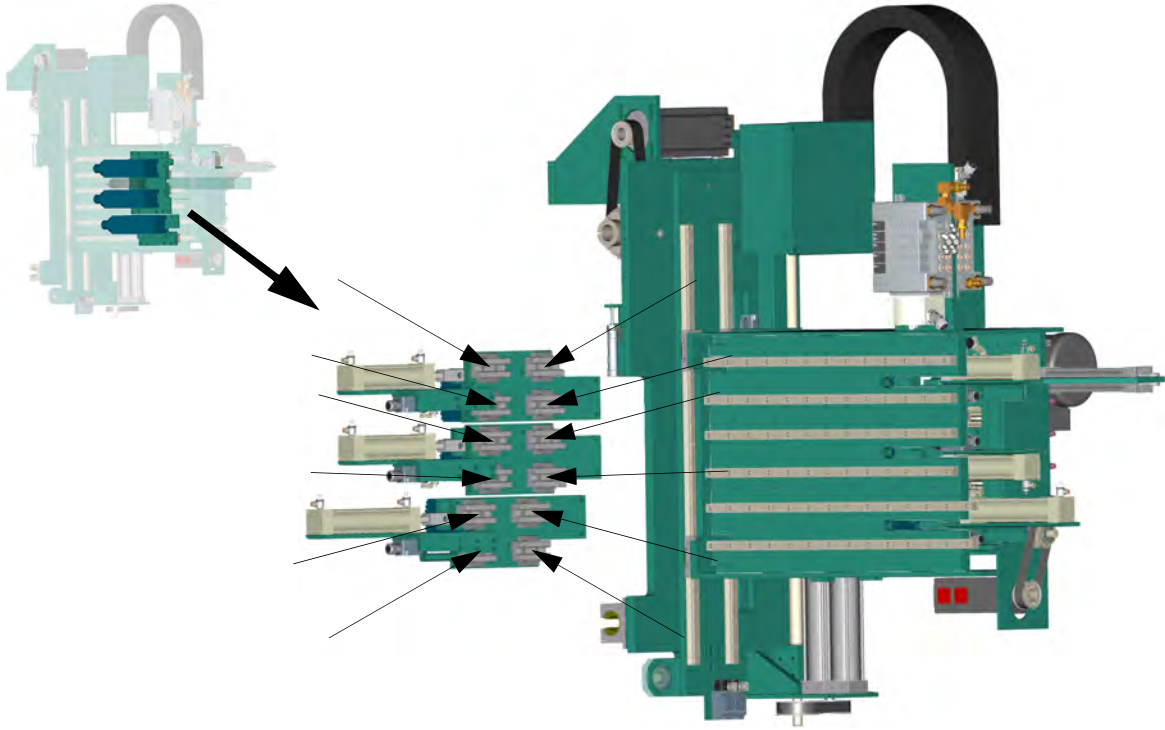

**Point to Point Drill (Optional)**

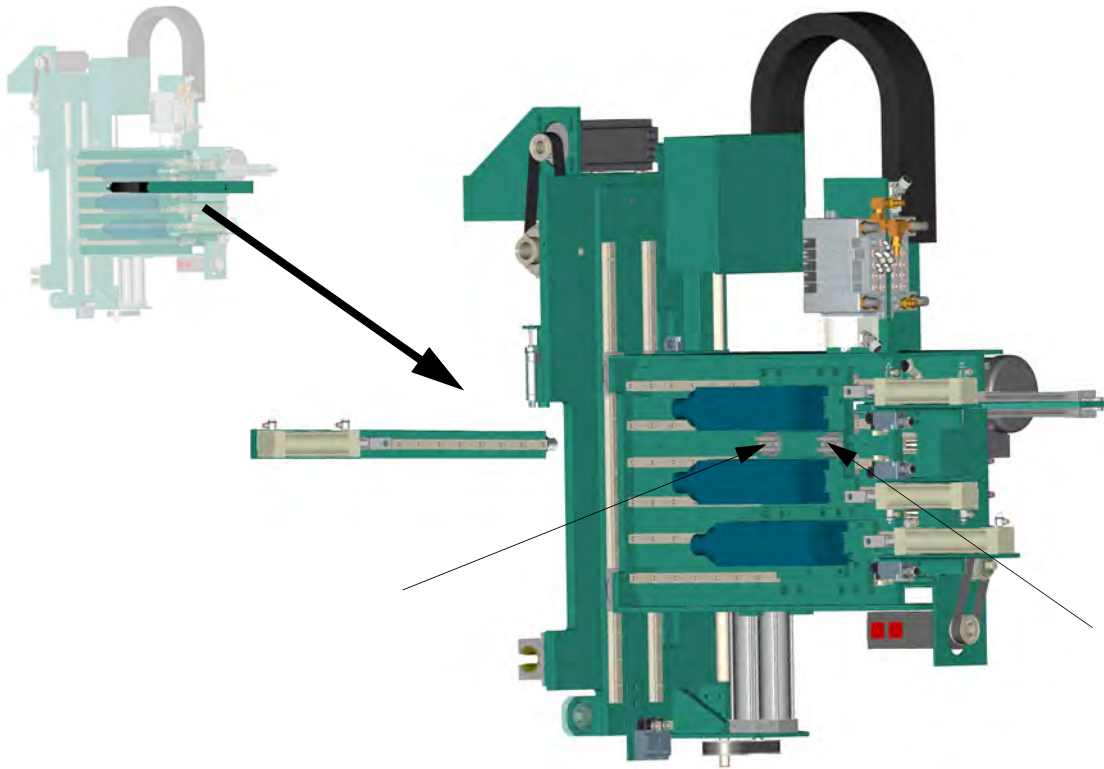

---

---

## Chisels

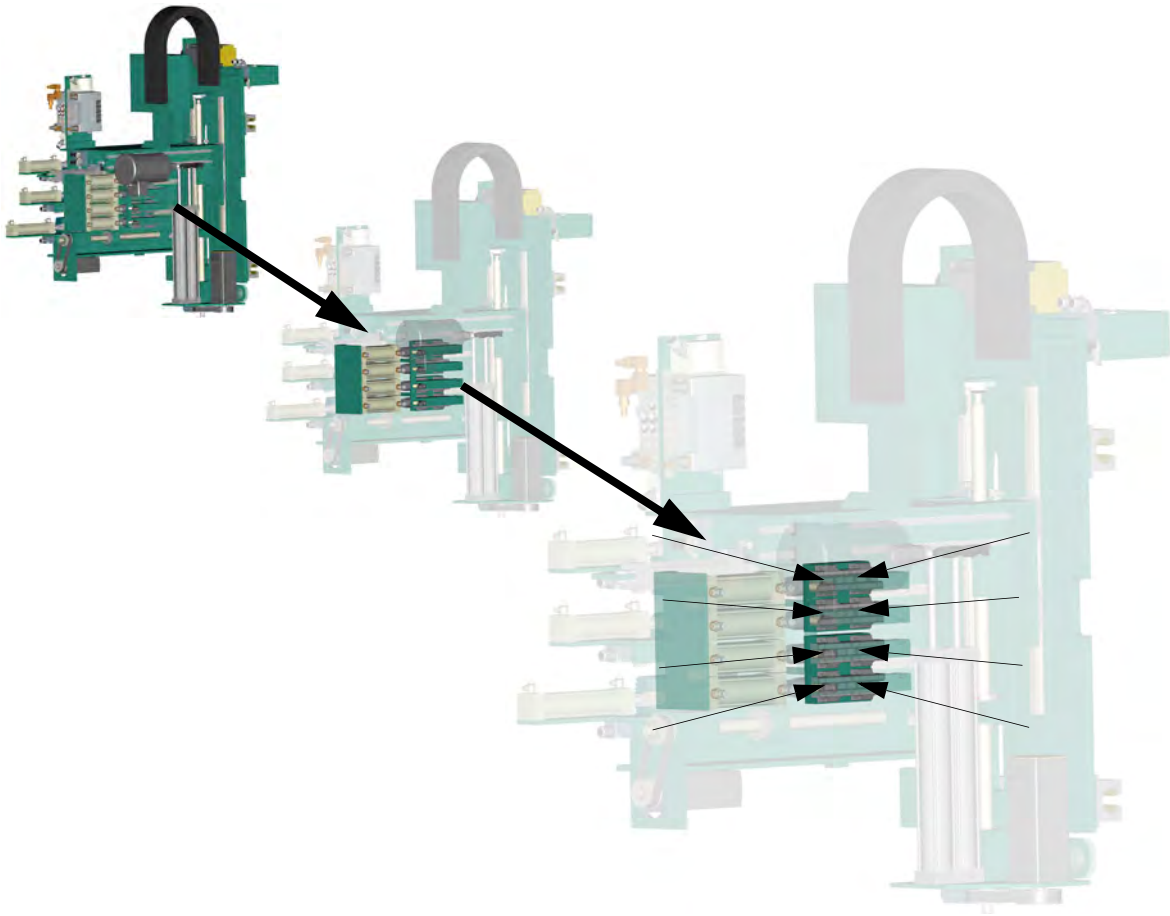

---

---

**Deep Mortise**

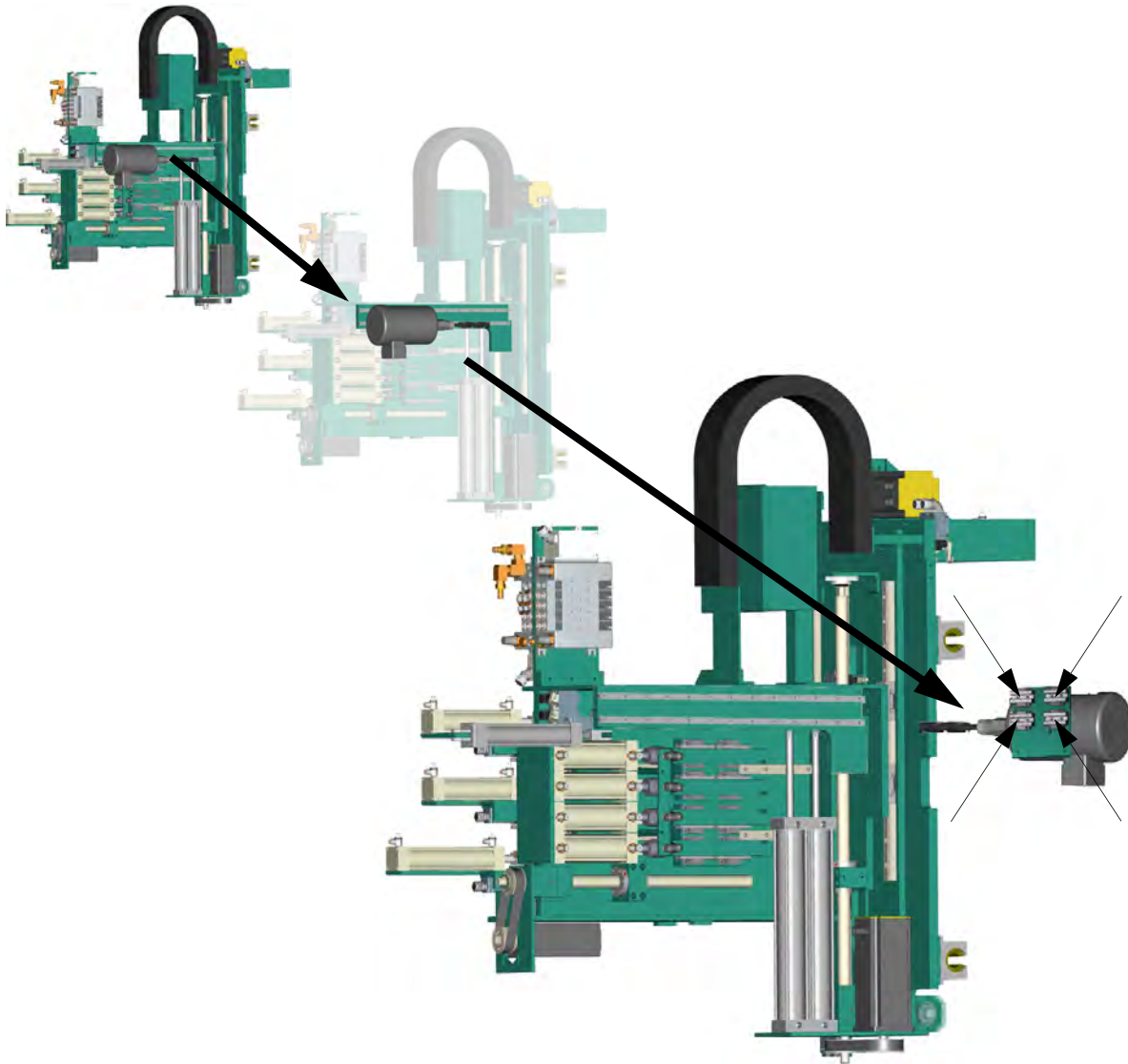

---

---

**CHAPTER 6**

**DLNCC**

This chapter shows the lubrication points for the KVAL Architect DLNCC.



## DLNCC - Grease Points

### Feed System

#### Fixed and Movable Fence

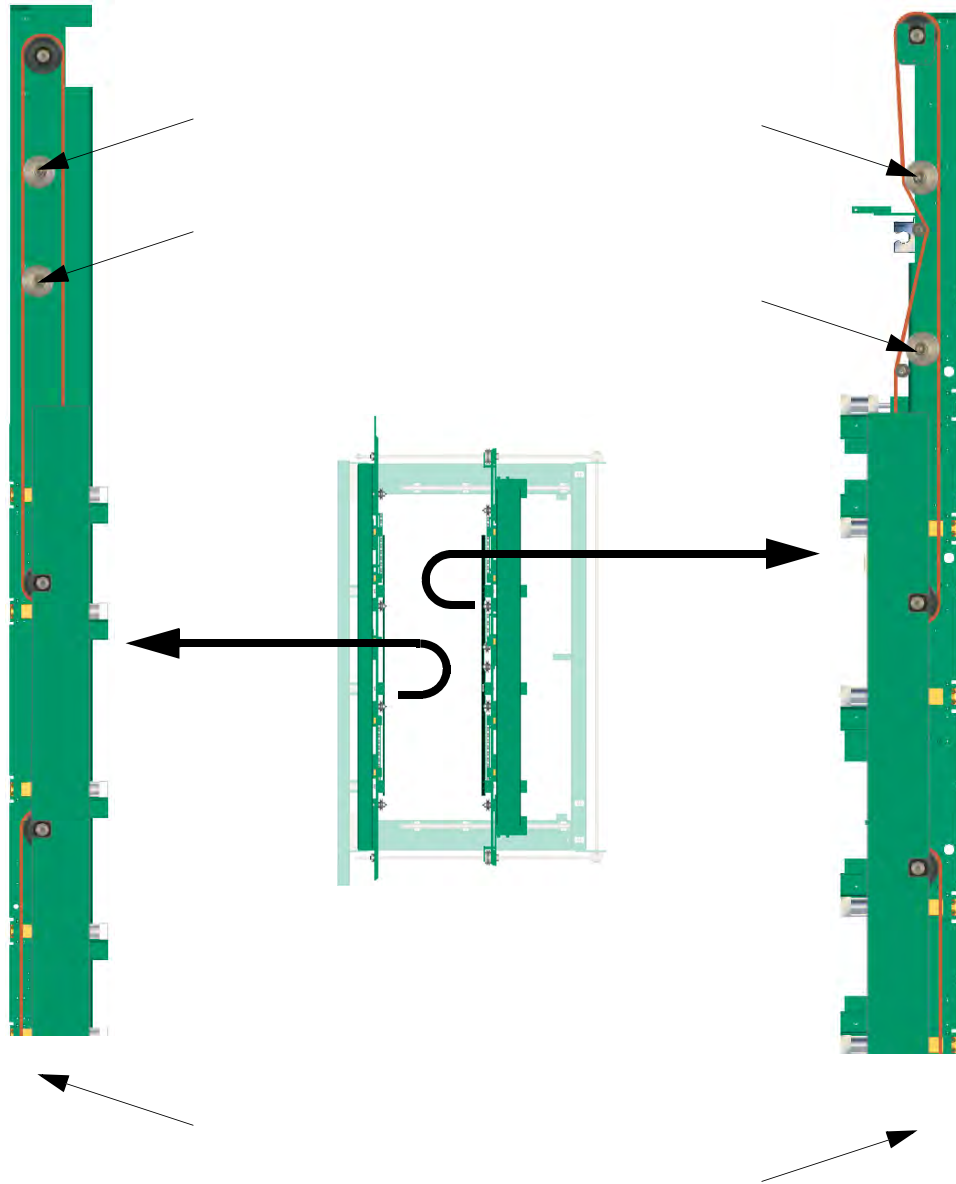

---

### Tool Changer

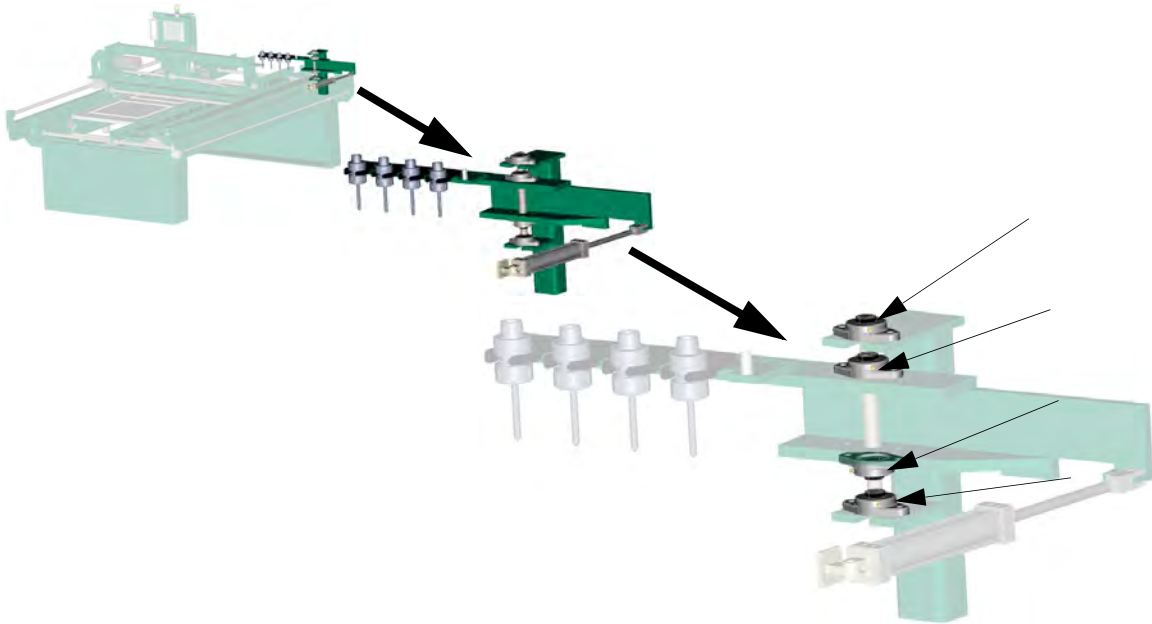

### X Axis

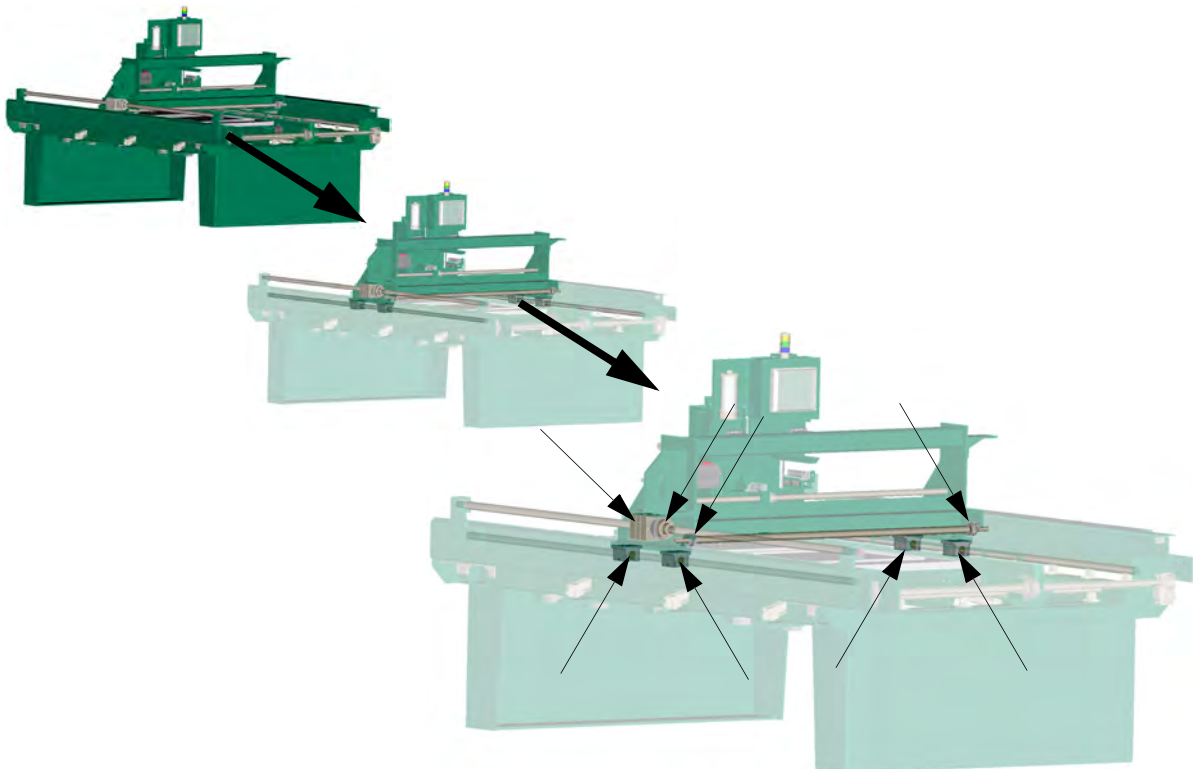

Y Axis

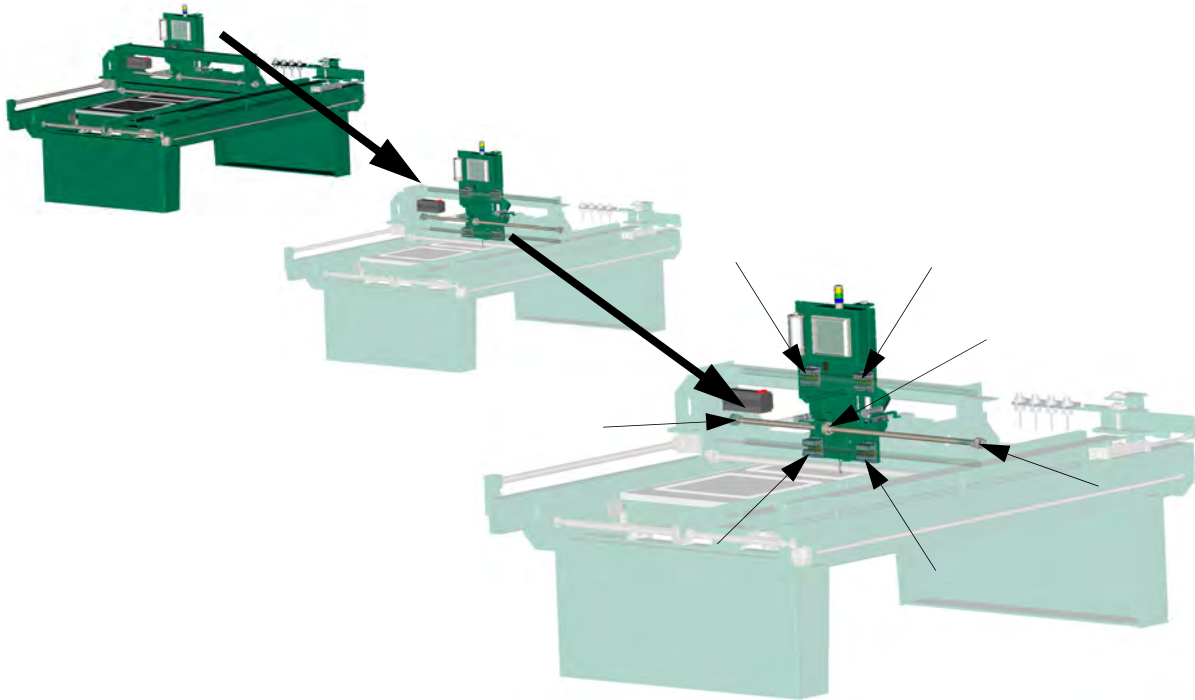

Cutting Head

Z Axis

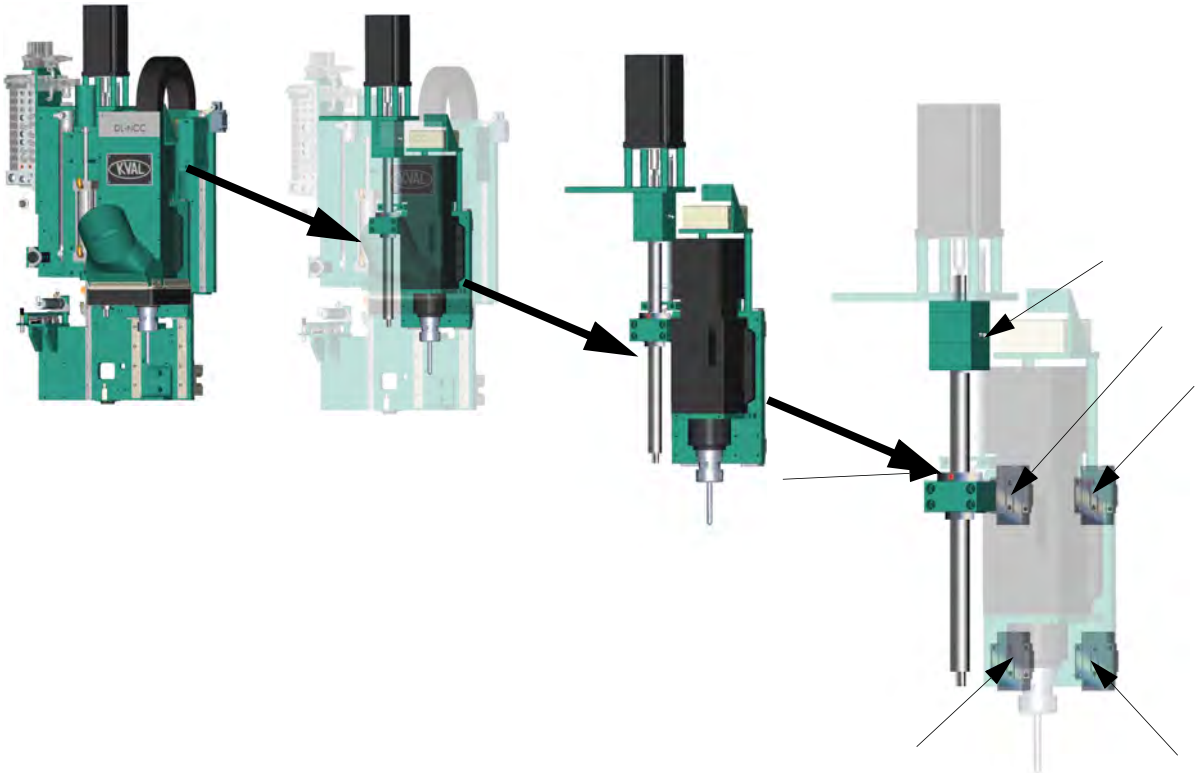

### Head Dust collection

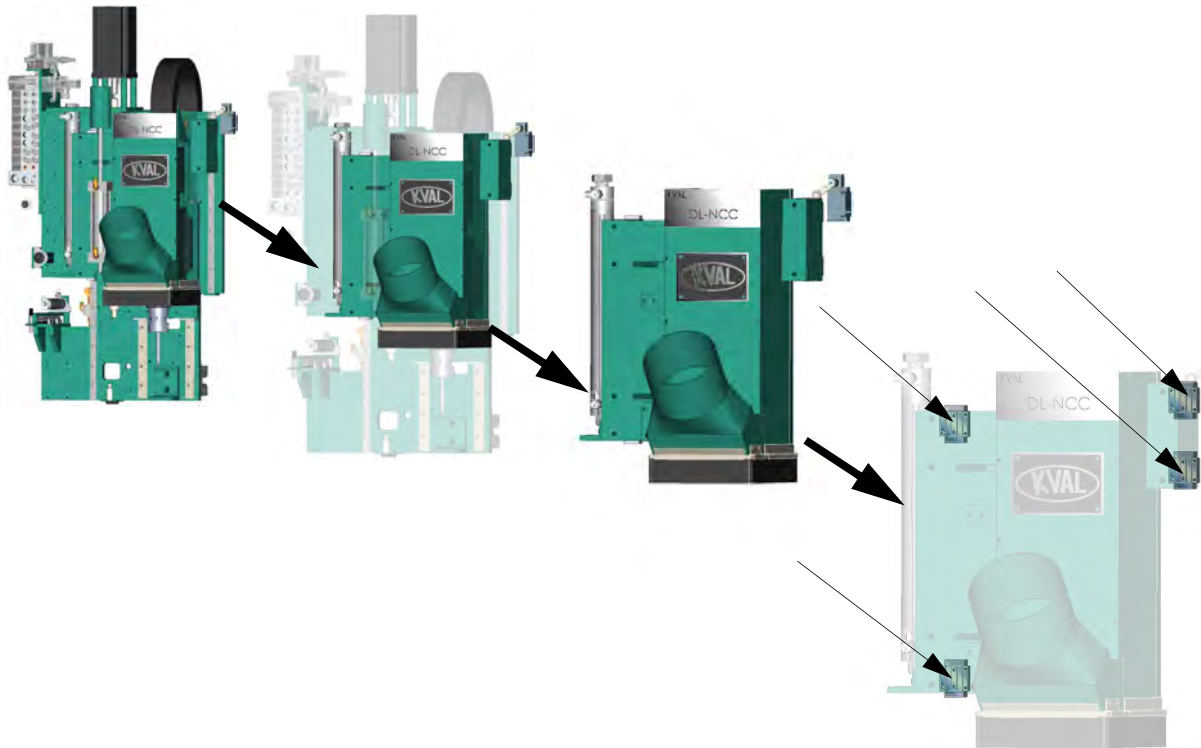

### Chisel (Optional)

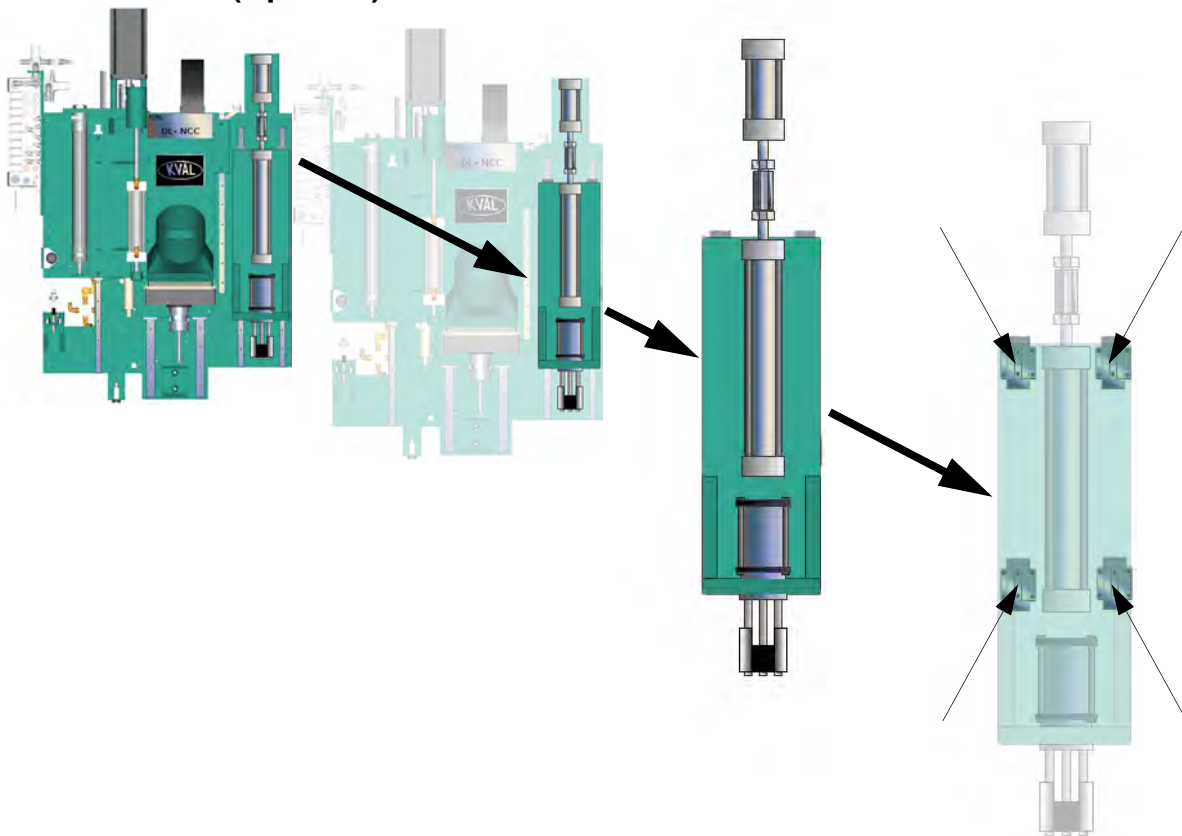

**Tool Calibration Bolt Eye**

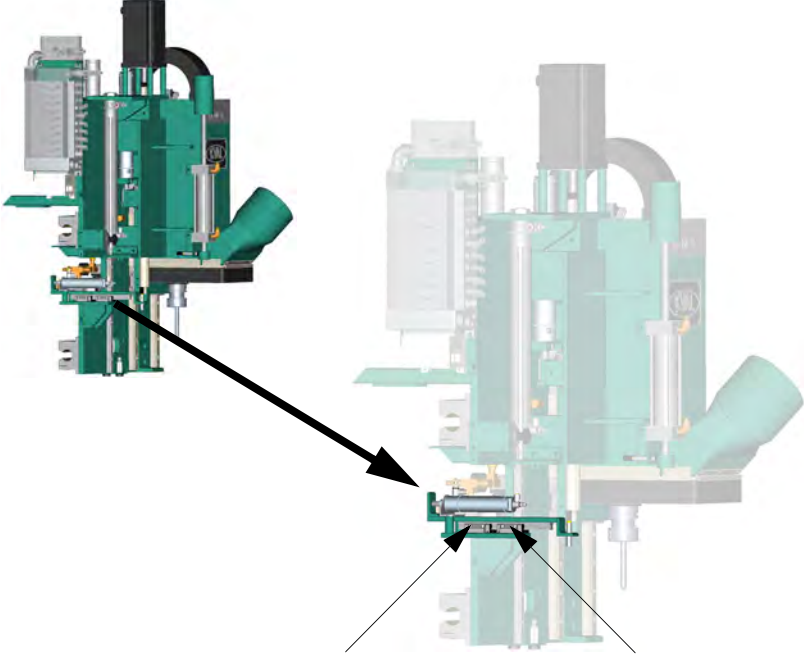



---

---

**CHAPTER 7**

**RAIL**

This chapter shows the lubrication points for the KVAL Rail.



## Rail - Grease Points

### Carriage

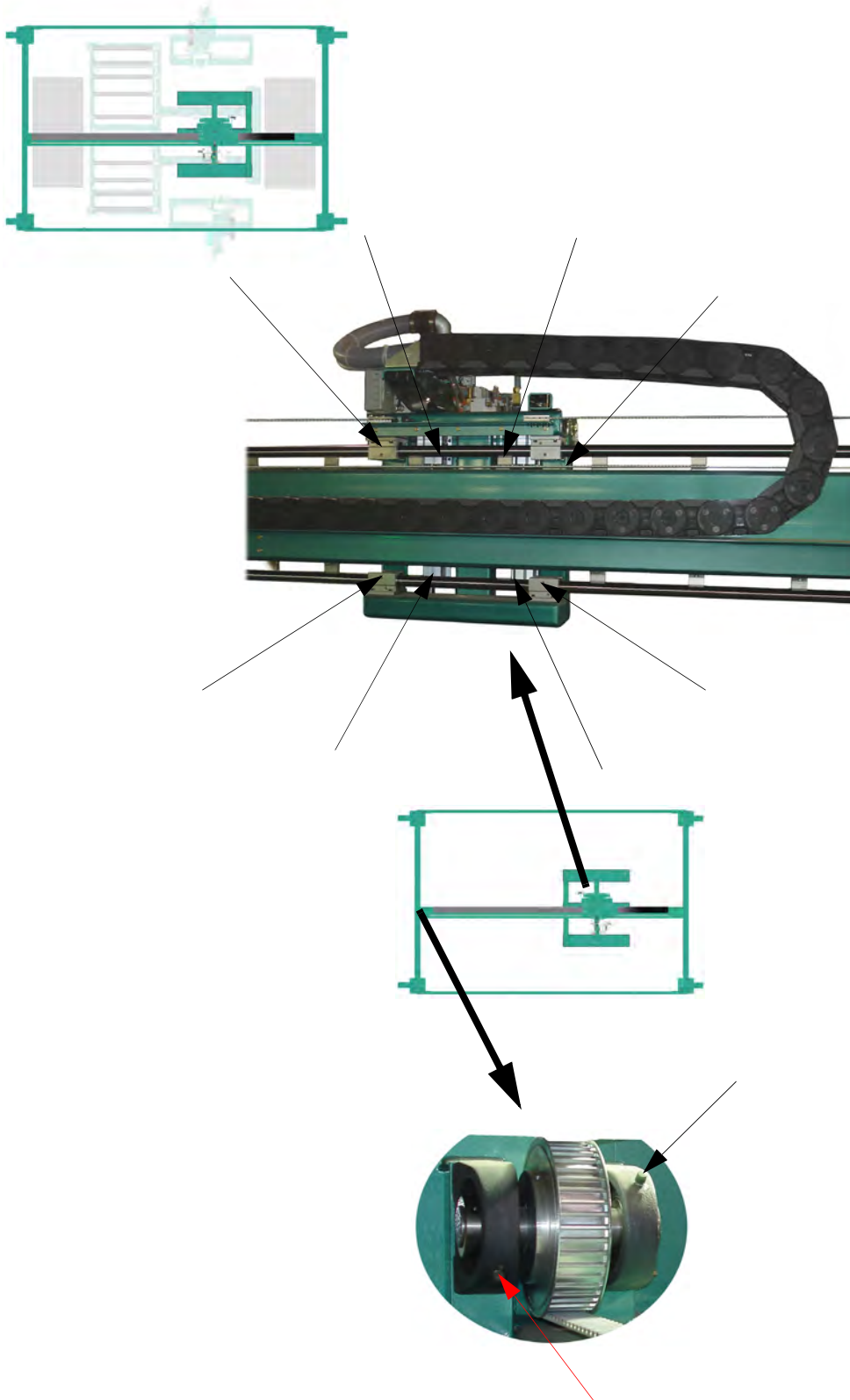

**Roll Table**

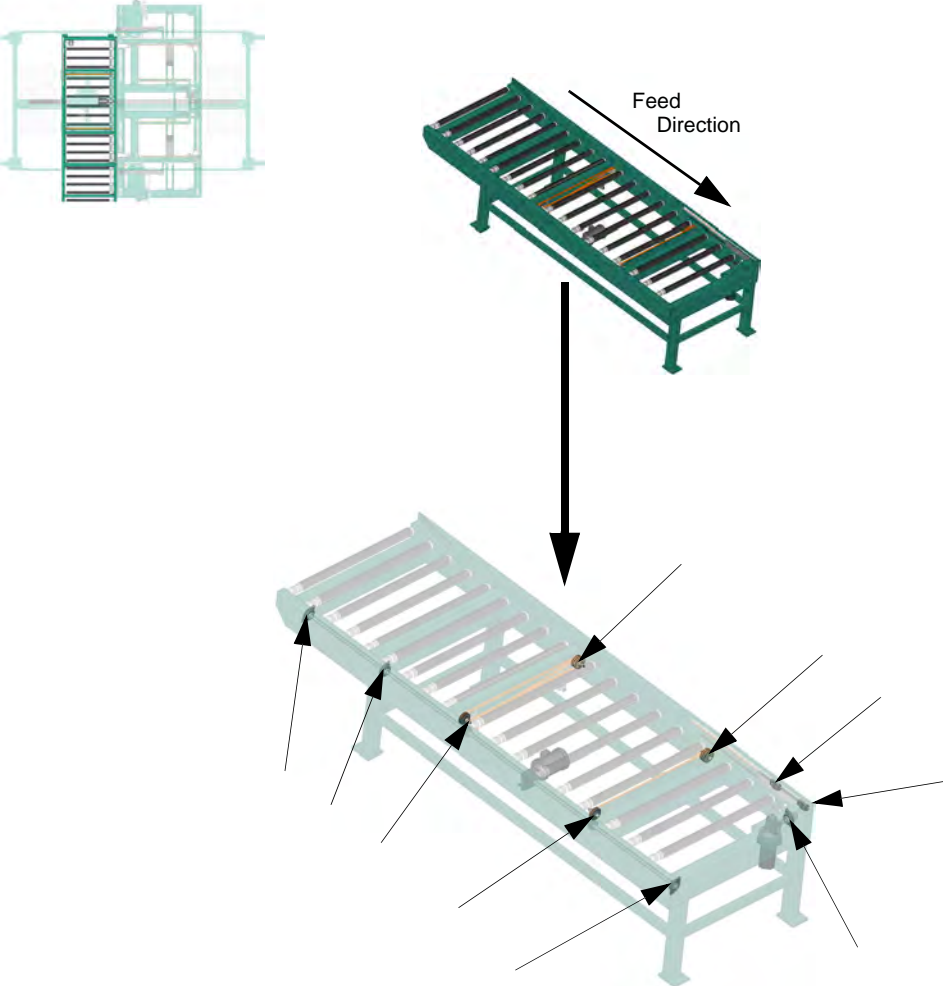

Rail

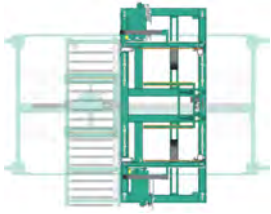

Fork Lift

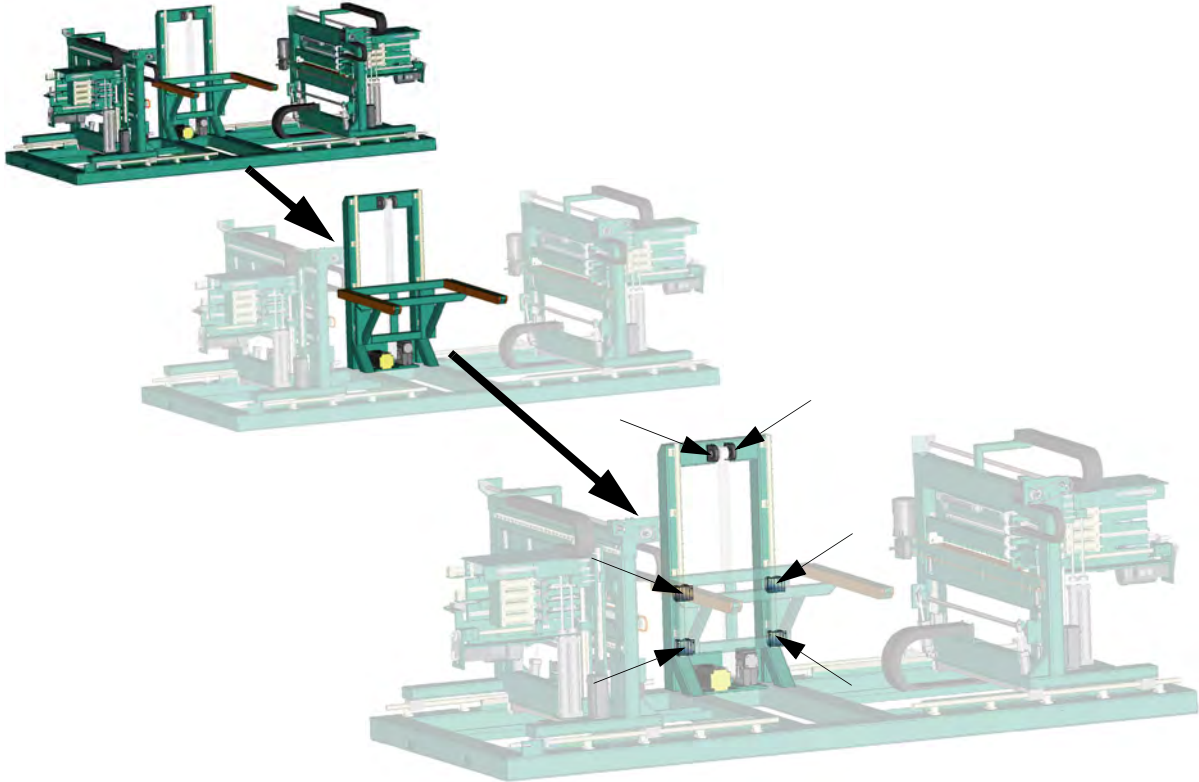

---

## Door Length Adjust

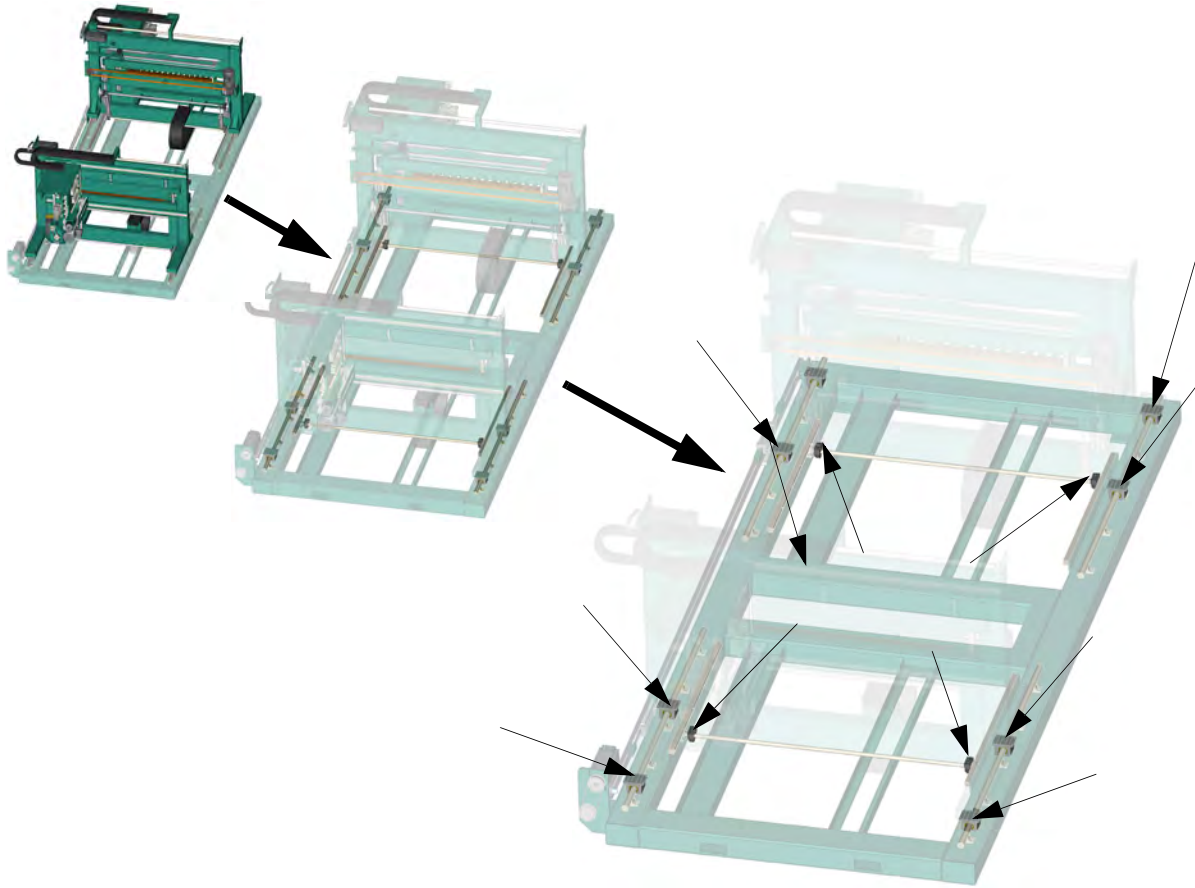

---

## Cutting Heads



## Cross Feed and Clamp

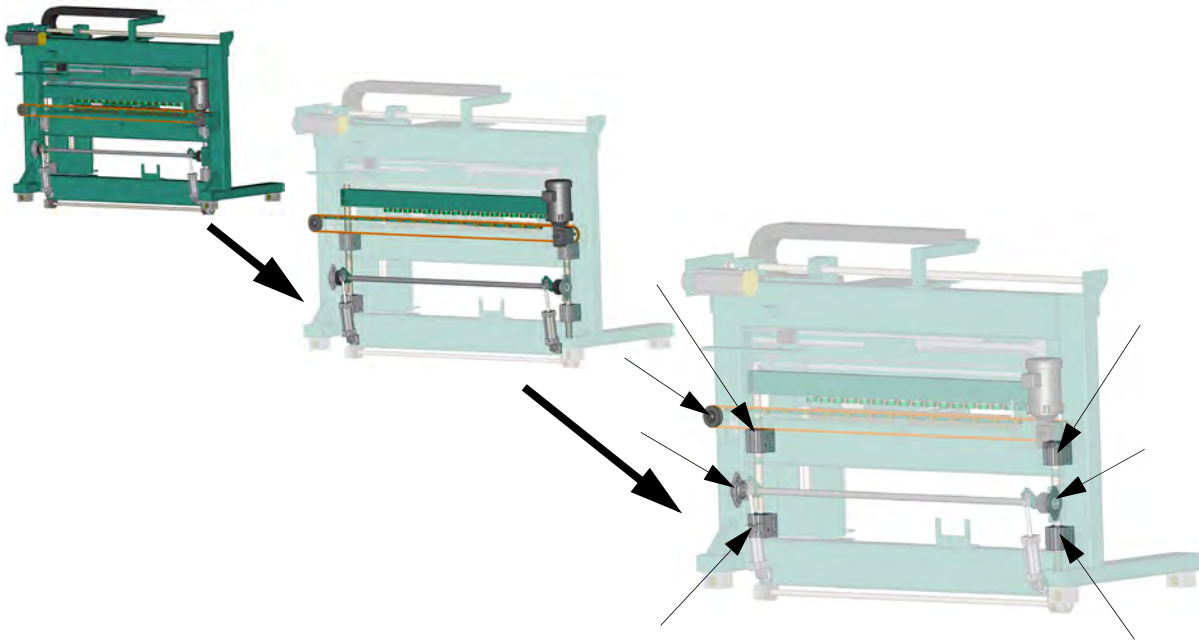

**Door Stops**

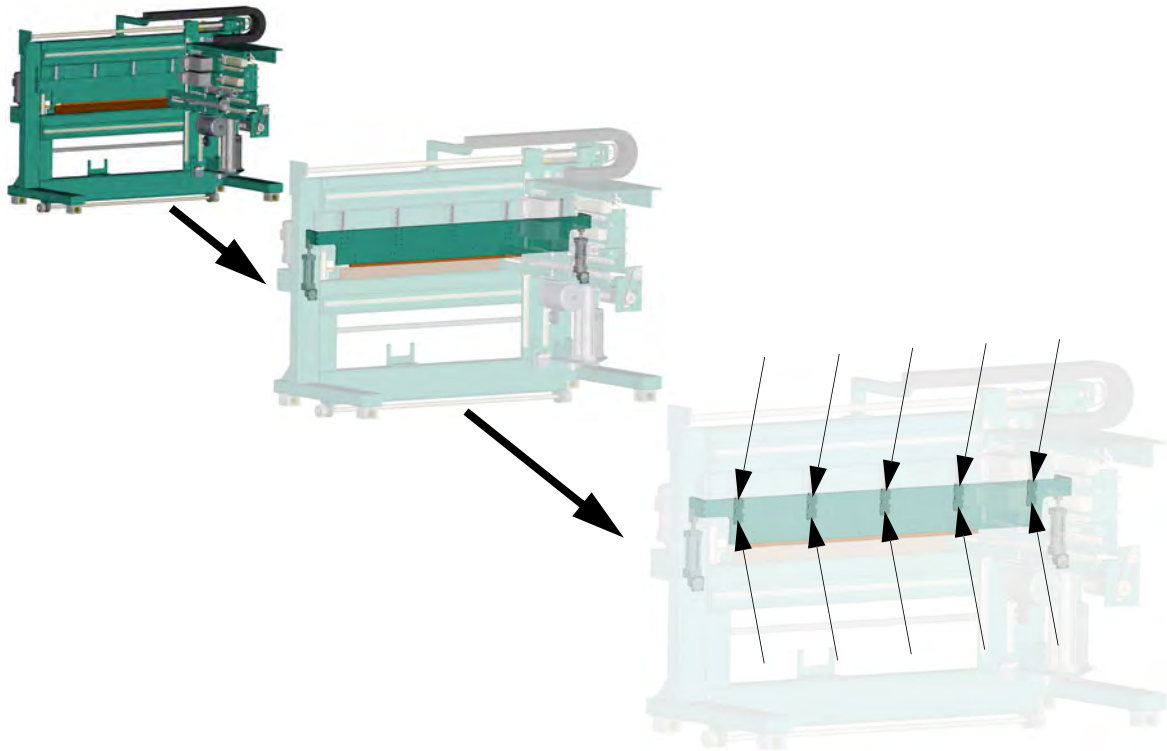

**Width Edge Feeler**

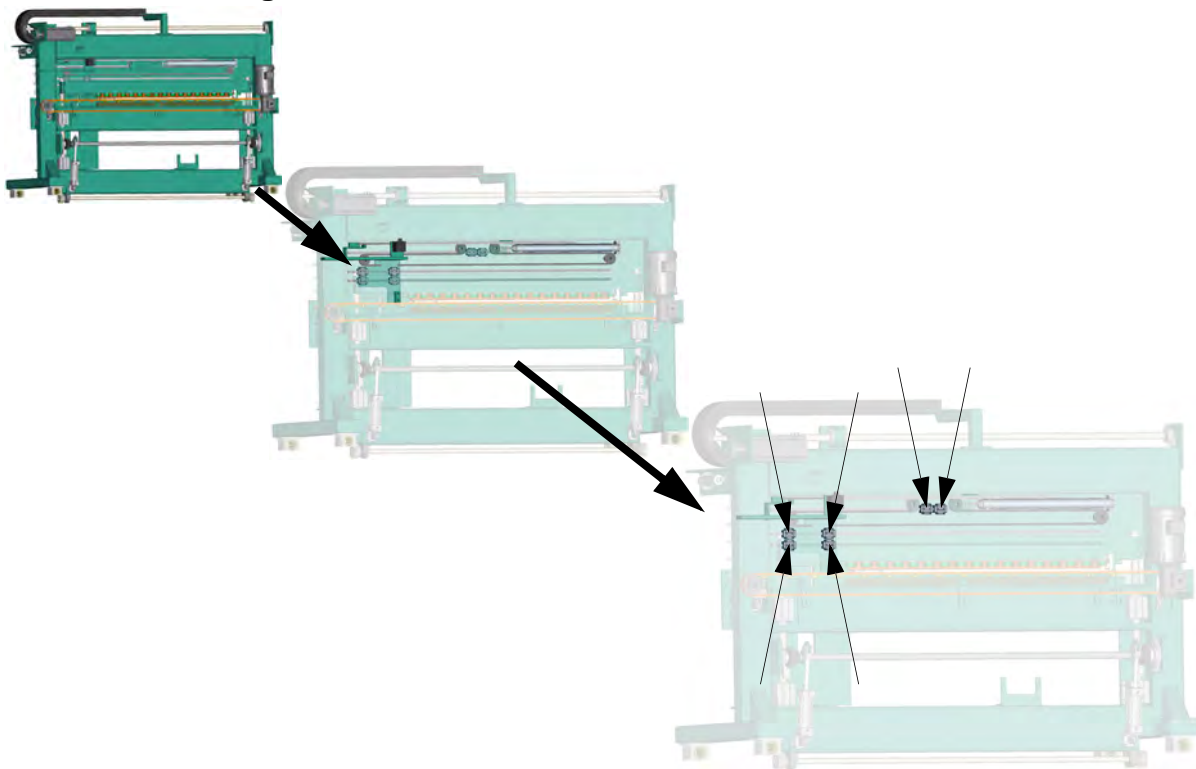

---

---

**Length Edge Feeler**

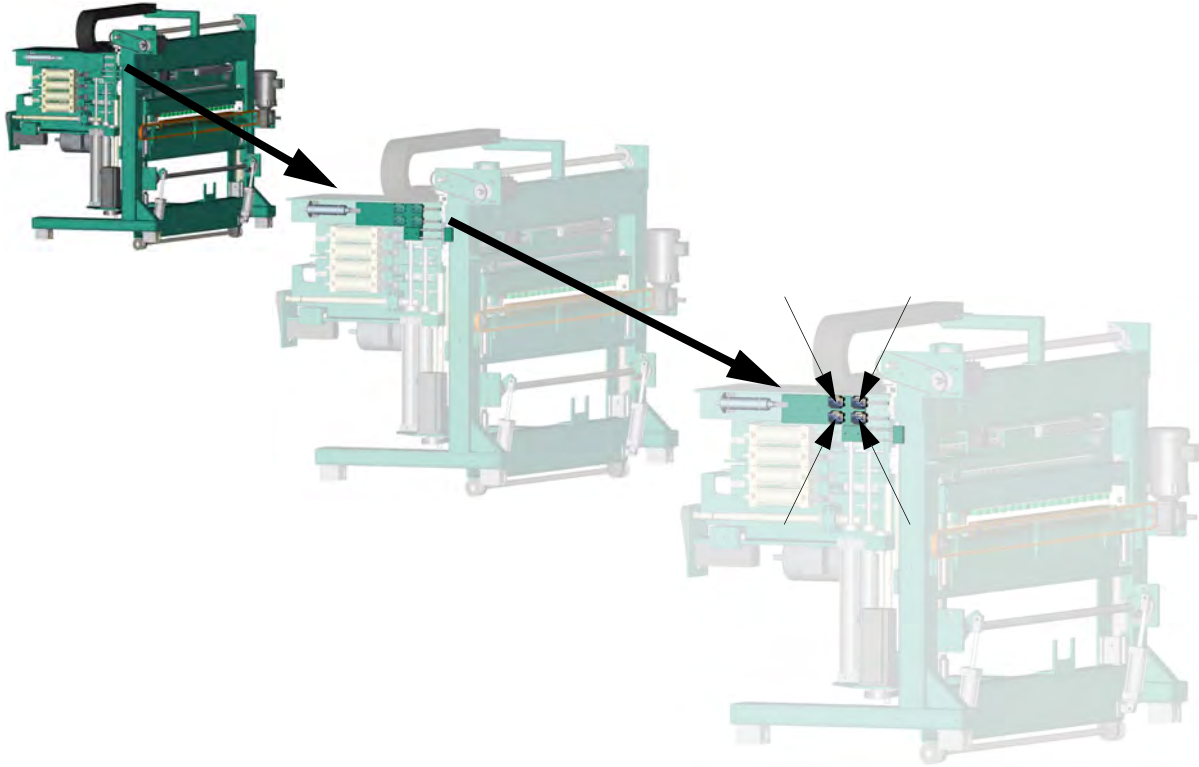

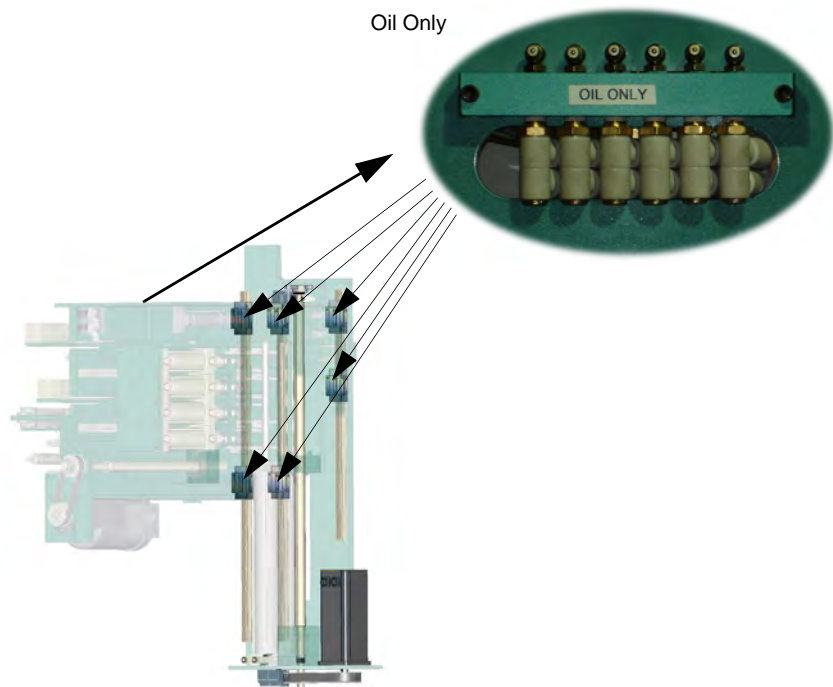
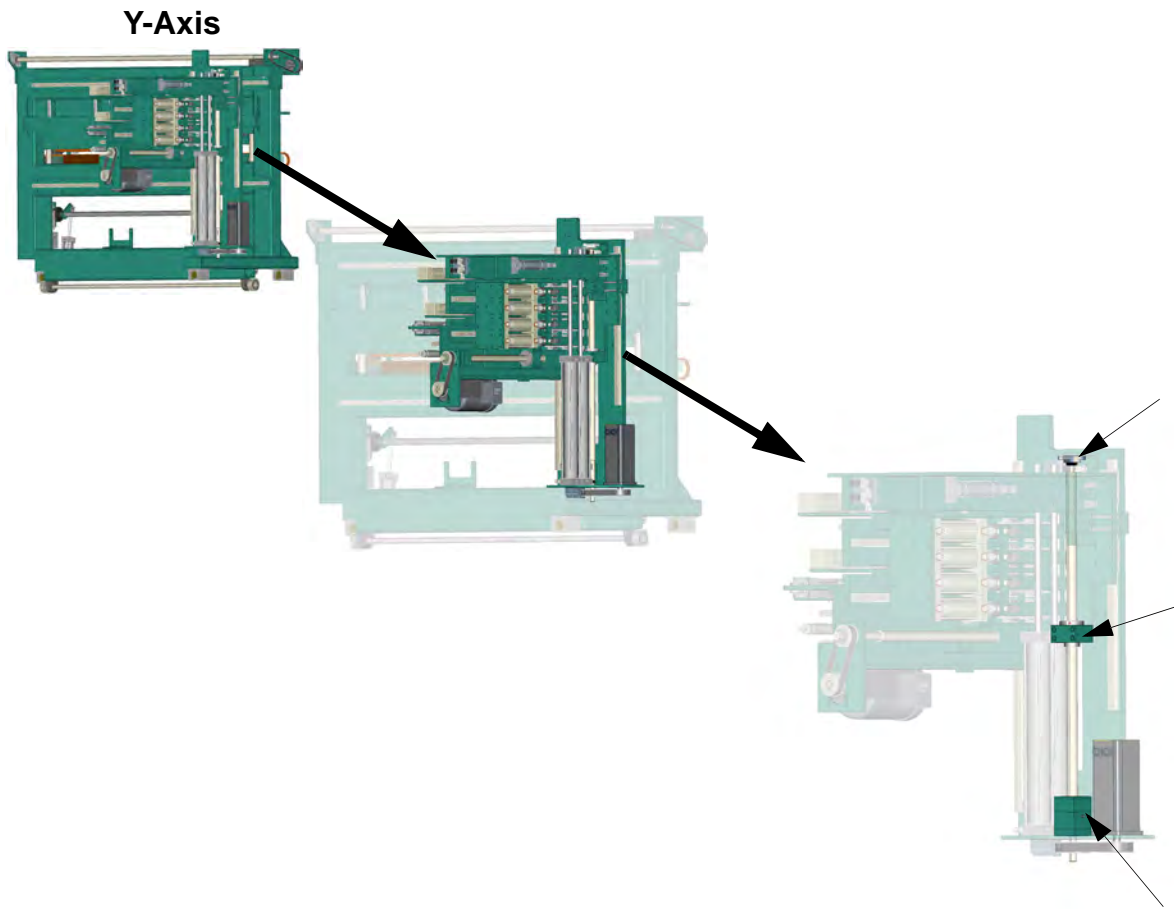

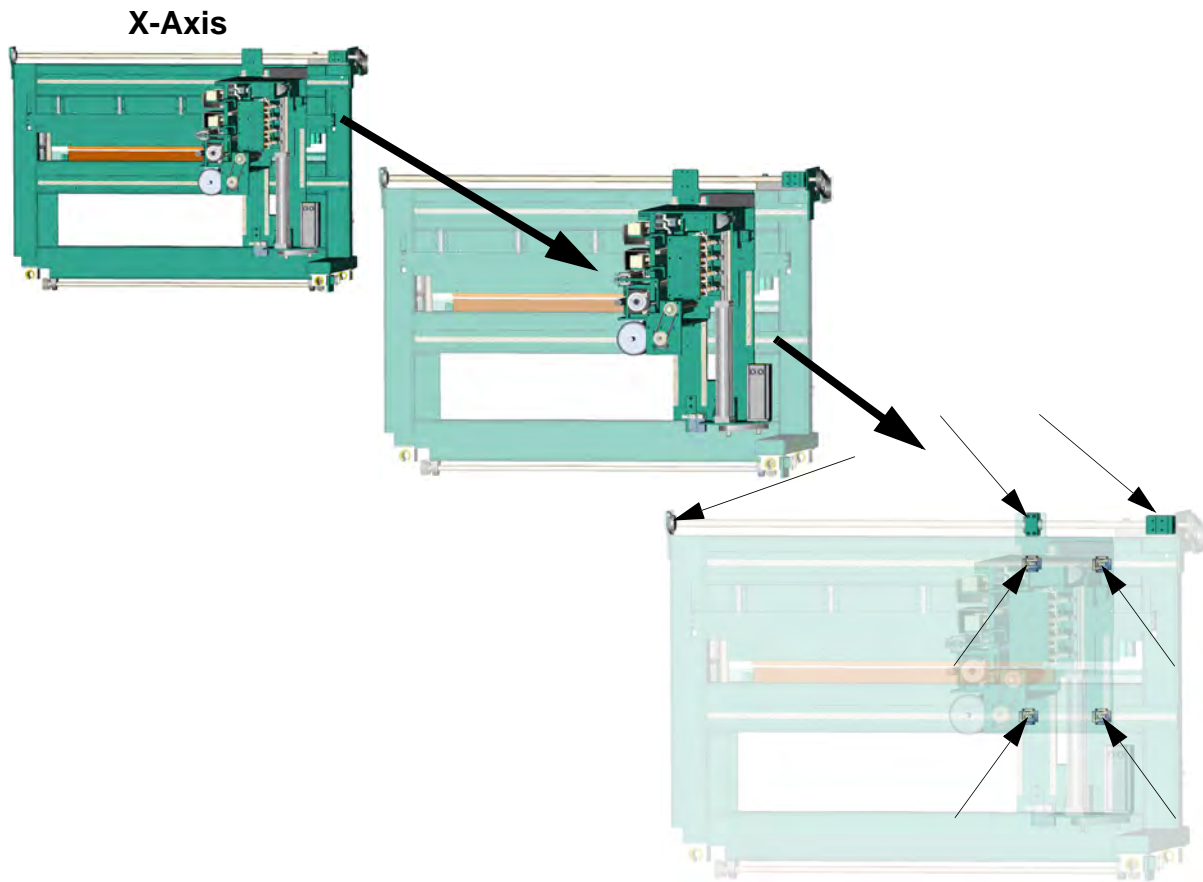

---

---

## Z-Axis

Chisel Side

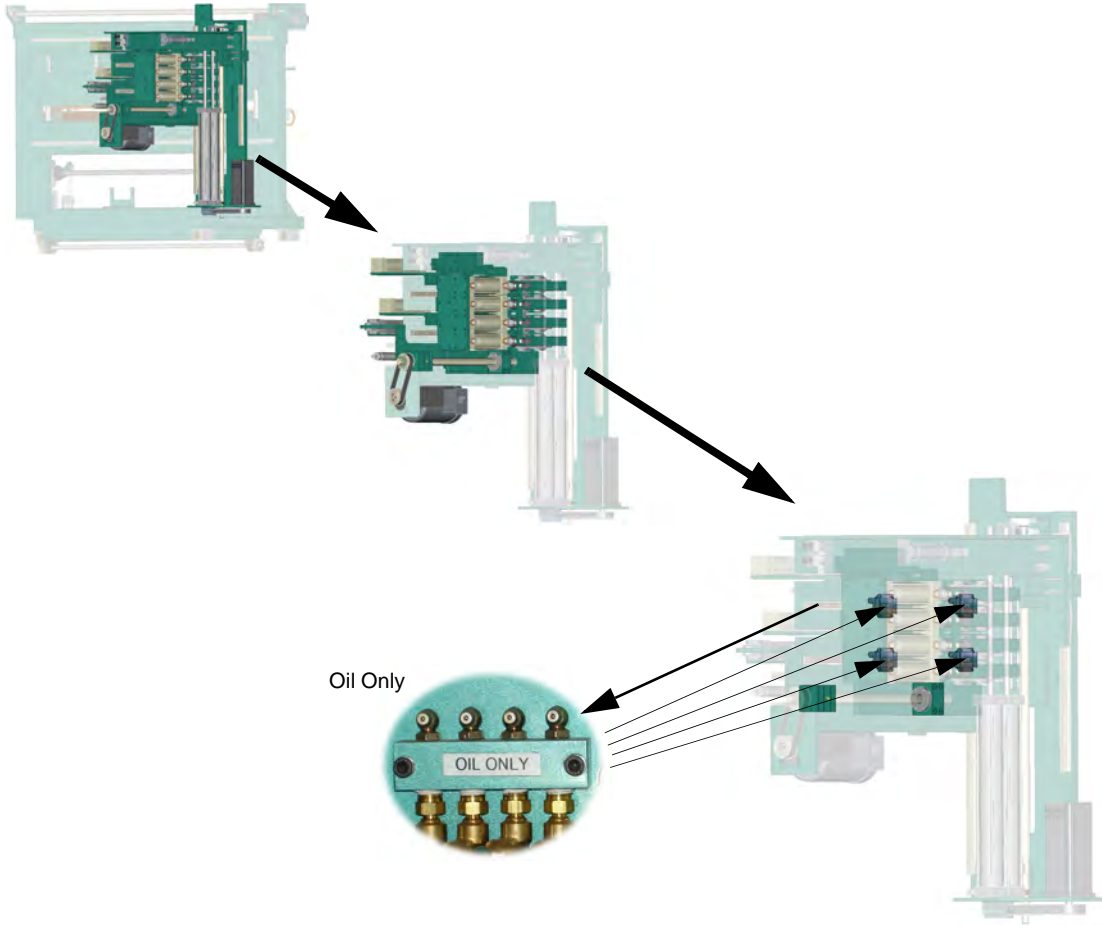

Chisel Side

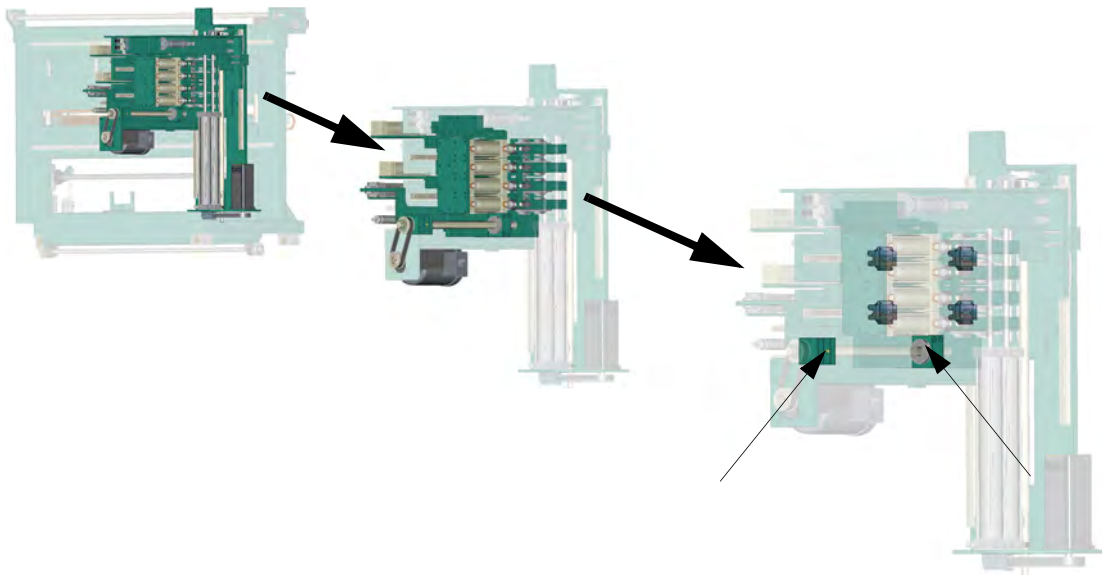

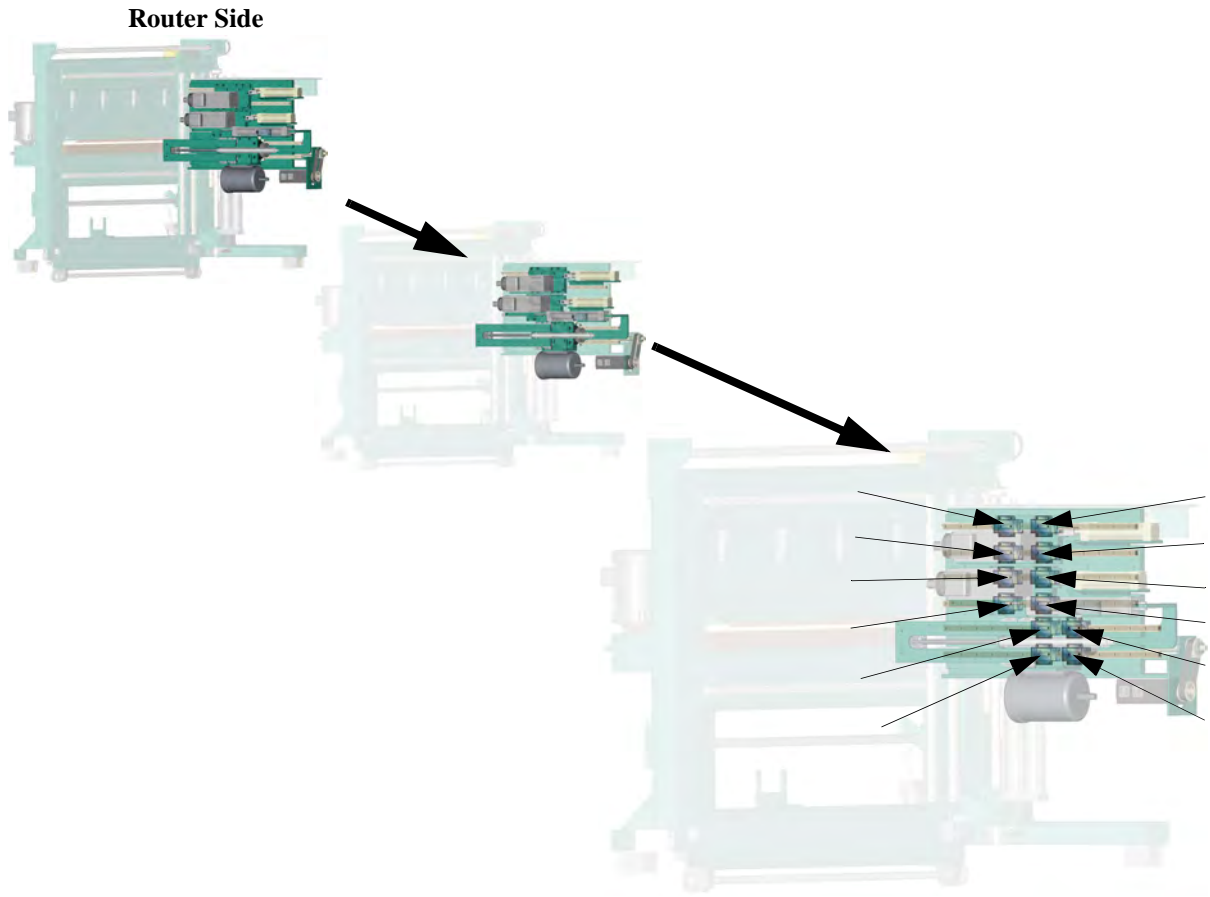

---

---

## Tools

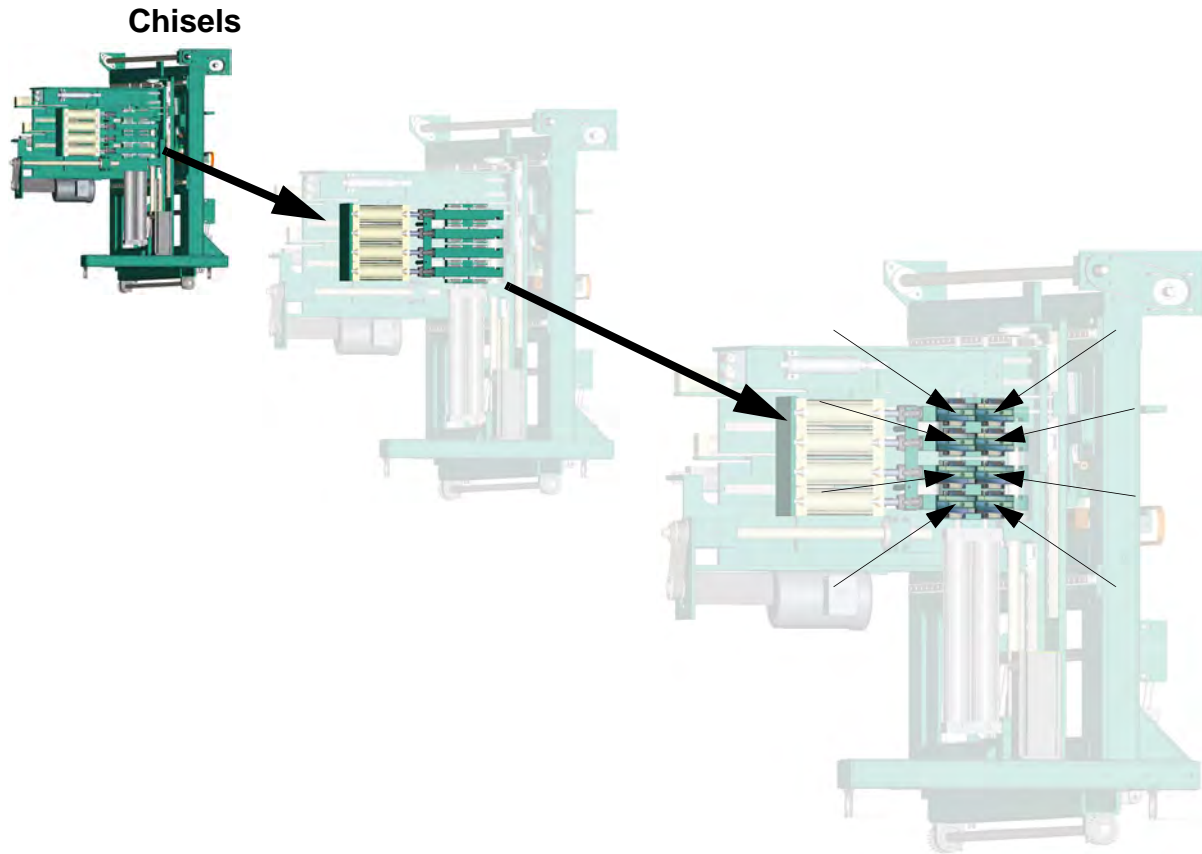

## Routers

See Z-Axis: Router Side page 13

### Deep Drill (Optional)

