

8 7 6 5 4 3 2 1

D

D

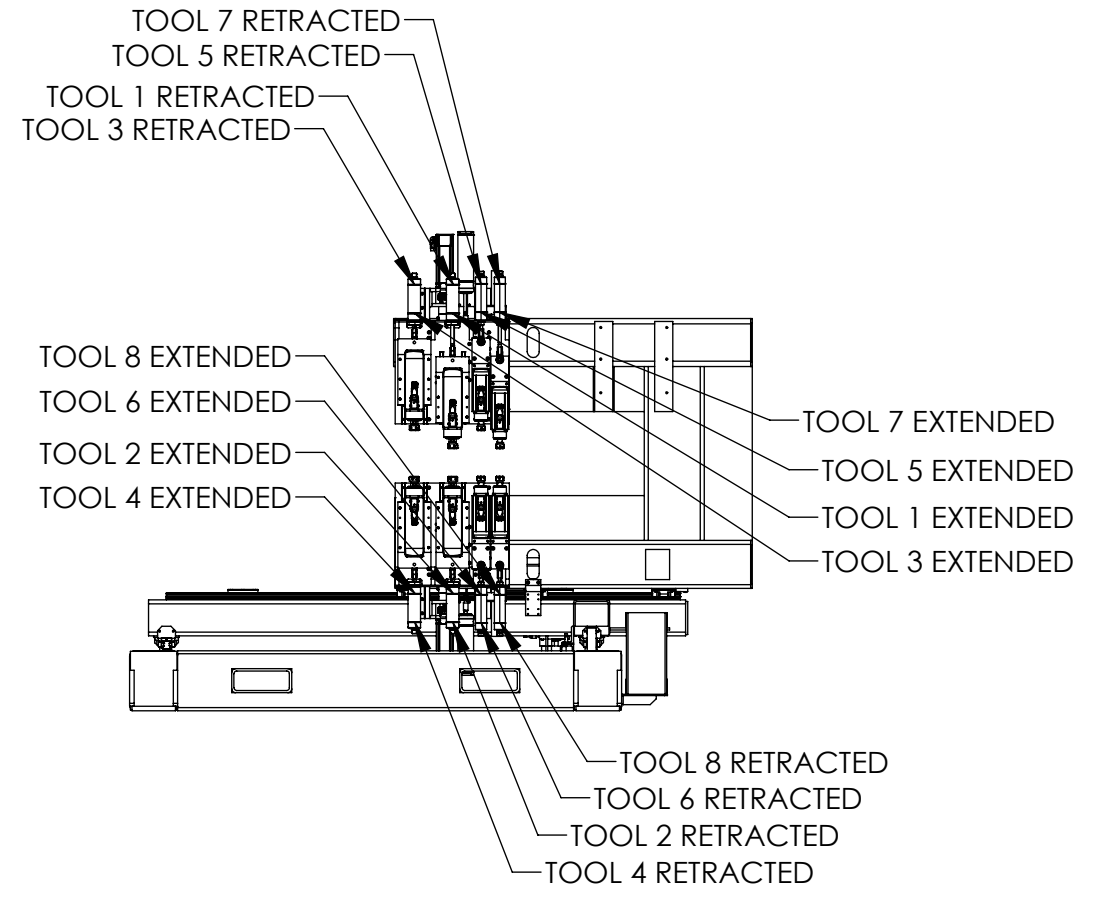

X-AXIS LUBRICATOR LEVEL LOW

Y-AXIS FWD EYE
Y-AXIS REV EYE
Y-AXIS HOME EYE

X-AXIS FWD EYE
X-AXIS REV EYE
X-AXIS HOME EYE

C

C

Z-AXIS TOP REV EYE
Z-AXIS TOP HOME EYE

Z-AXIS TOP FWD EYE

B

B

VB#177-R2-200

Y-AXIS LUBRICATOR LEVEL LOW

Z-AXIS BOTTOM FWD EYE

Z-AXIS BOTTOM HOME EYE
Z-AXIS BOTTOM REV EYE

A

A

PART NUMBER:
177-R2_ELE

SCALE
1:32

SHEET 1 OF 3

Printed Thursday, August 22, 2024

REV
1

8 7 6 5 4 3 2 1

8 7 6 5 4 3 2 1

OPTION EF (EDGE FACE PLATE)

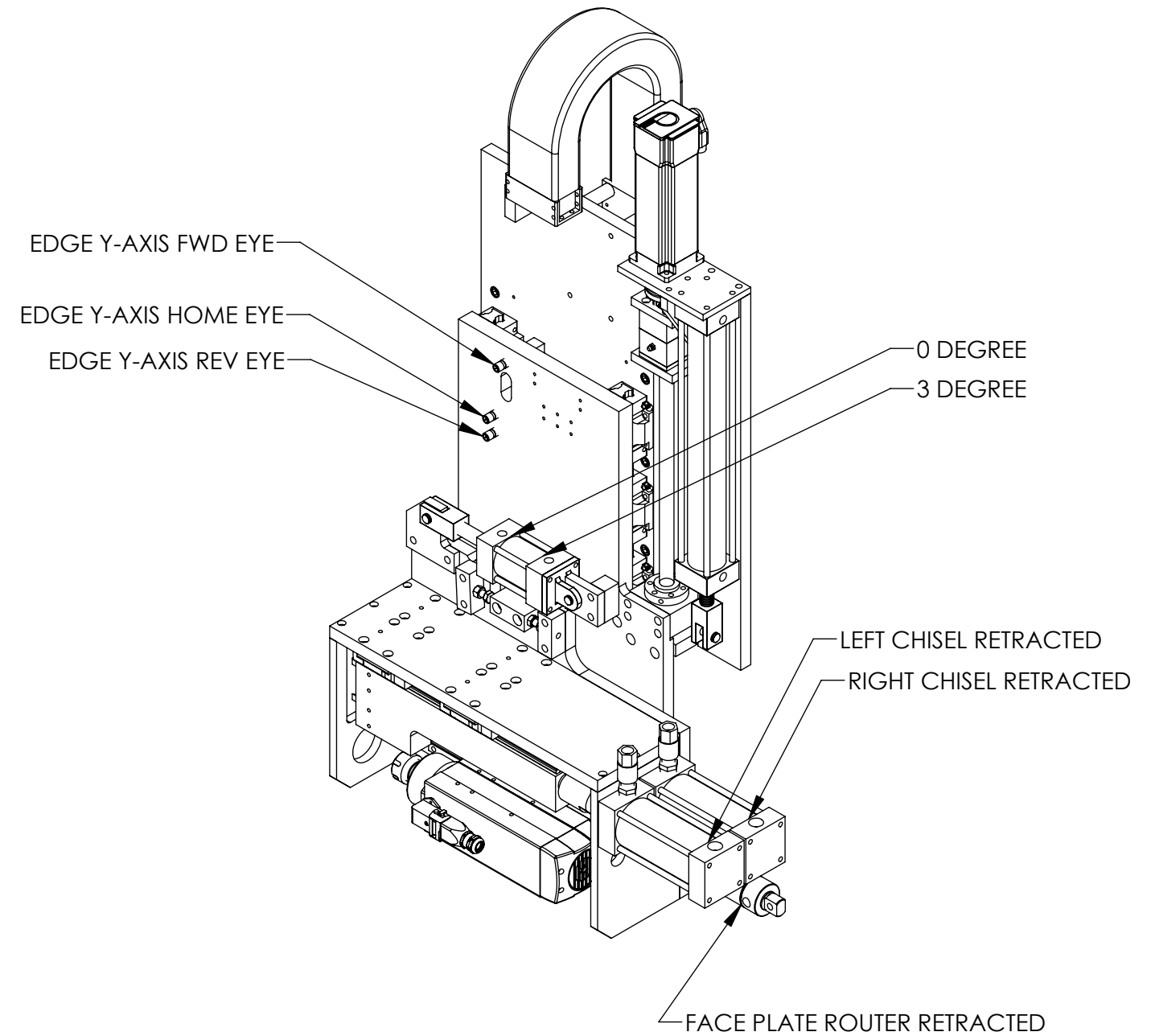
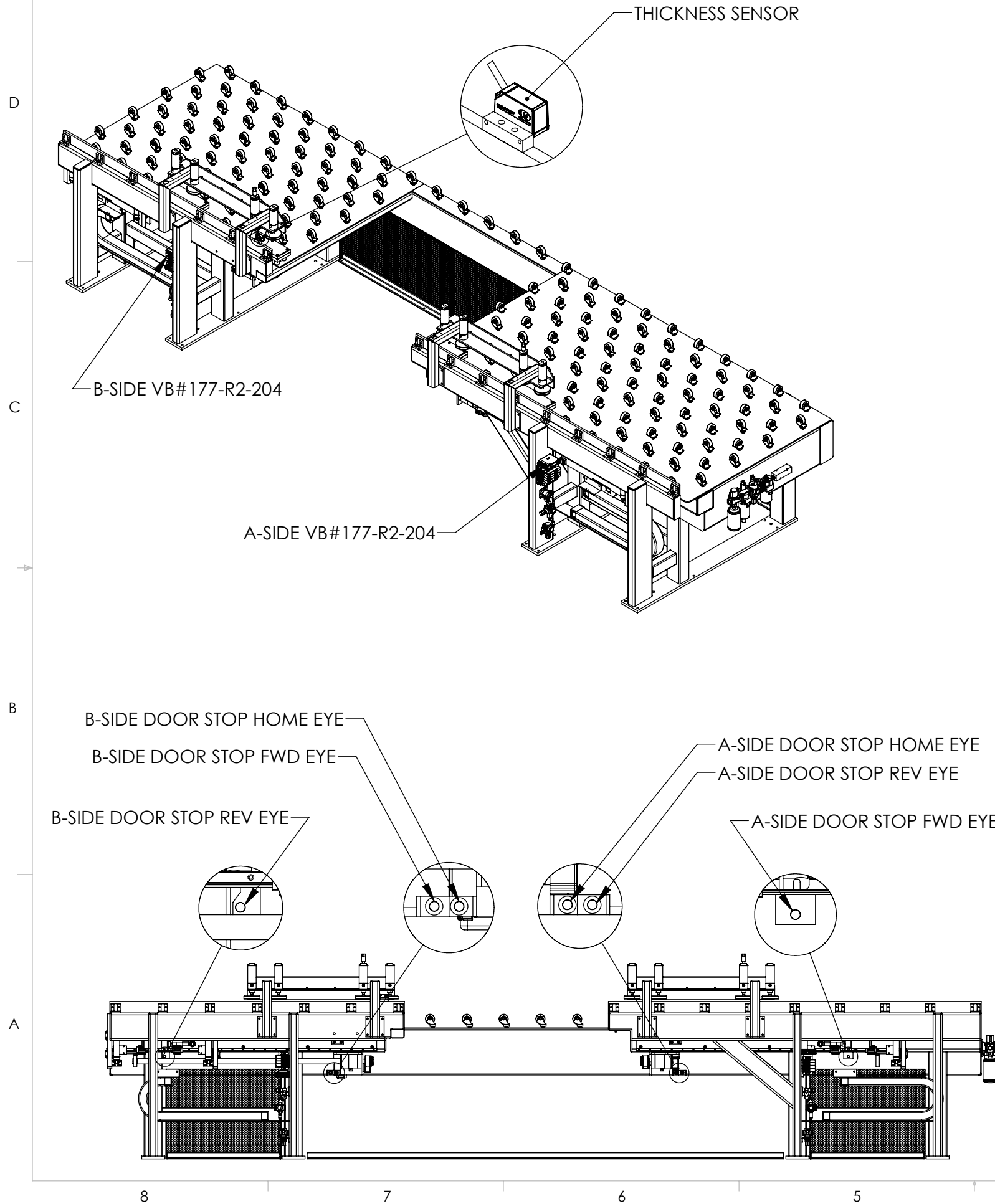

KVAL INC.
825 PETALUMA BLVD. SO.
PETALUMA, CA 94952
(707) 762-7367 FAX (707) 762-0621

177-R2_ELE

SCALE 1:26 SHEET 2 OF 3 REV 1

Printed Thursday, August 22, 2024



8 7 6 5 4 3 2 1

OPTION F (AUTO FEED AND POSITION)

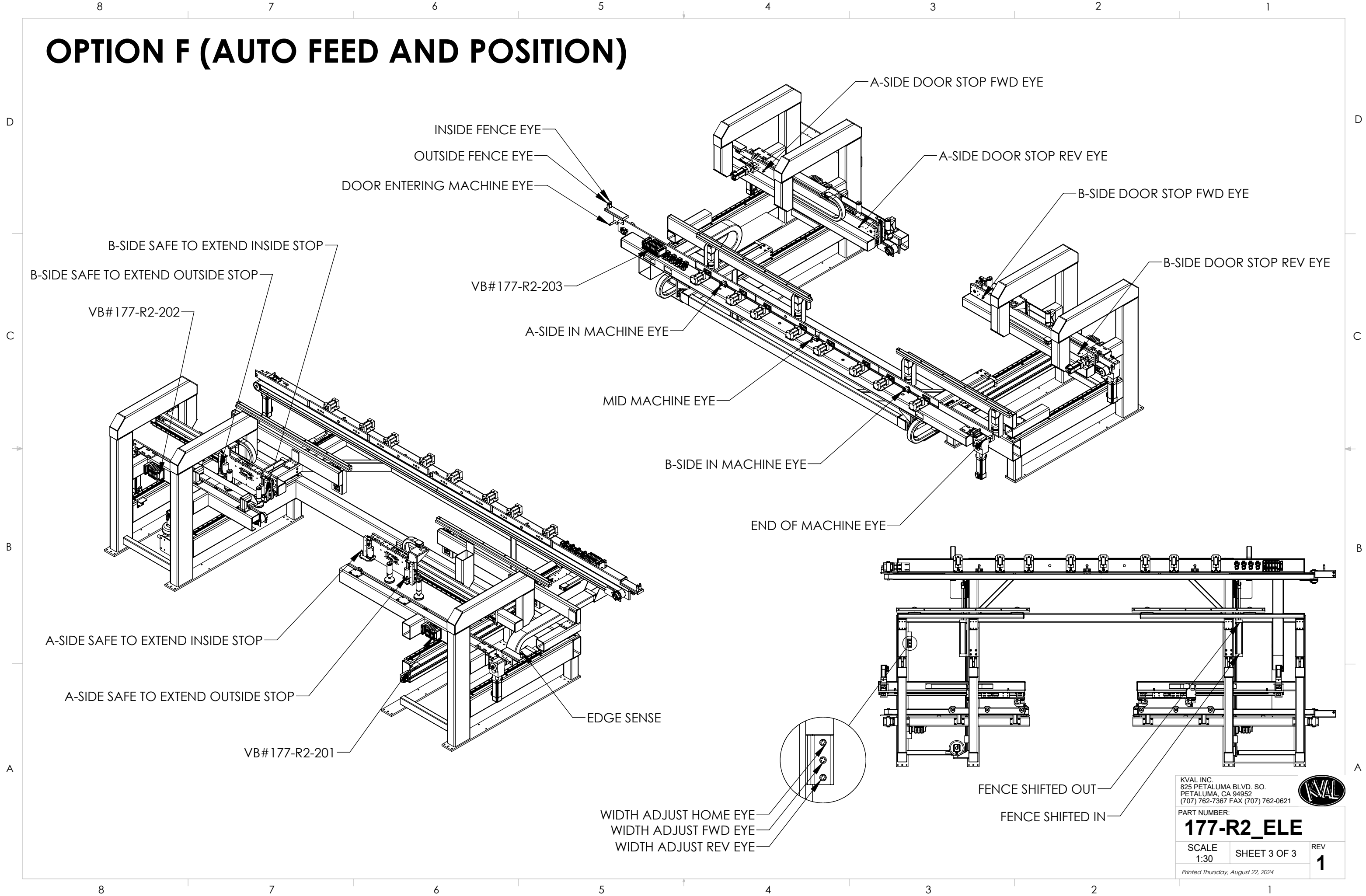

KVAL INC.
 825 PETALUMA BLVD. SO.
 PETALUMA, CA 94952
 (707) 762-7367 FAX (707) 762-0621

177-R2_ELE

SCALE 1:30 SHEET 3 OF 3 REV 1

Printed Thursday, August 22, 2024